

ENGINE 139QMA
139QMB

MAINTENANCE MANUAL

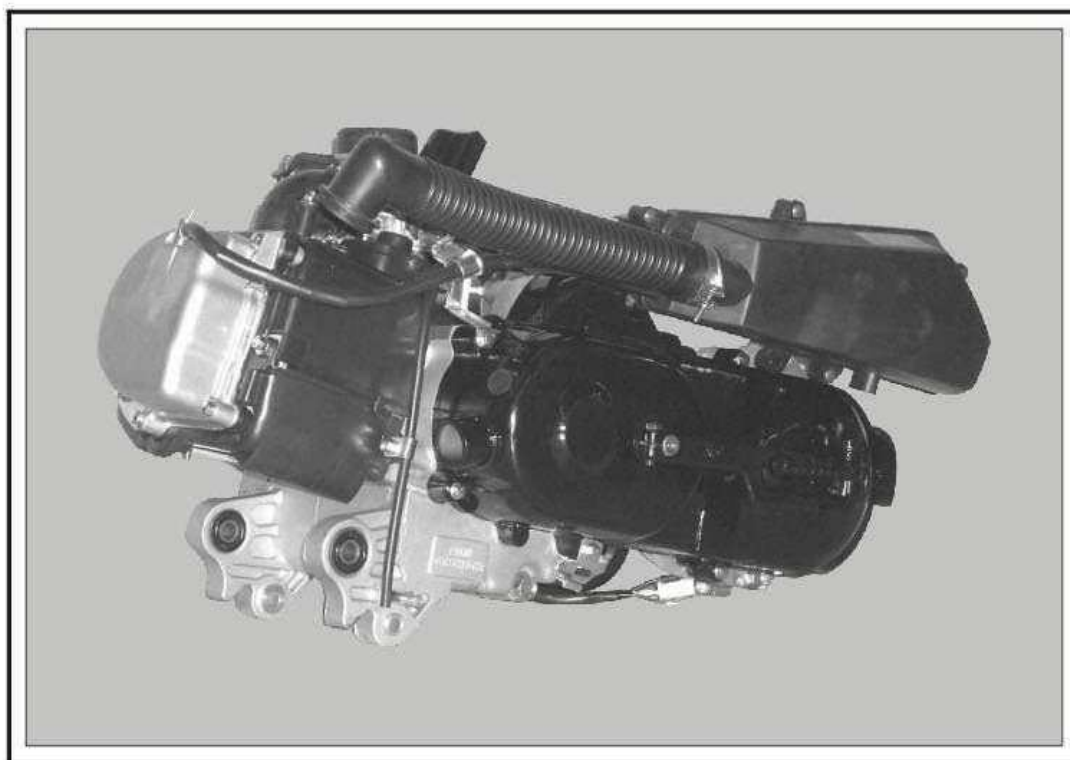

FOREWORD

This manual is compiled for your use, maintenance and inspection of your motorcycle. For detailed information about structure and appearance of your motorcycle and parts, please refer to BT49(50) motorcycle parts catalog and illustration book.

Disassembling and assembling of motorcycle parts can be effected by removing the coerture and interference fittings.

This manual is based on the structures of the present types Baotian 139QMA and 139QMB. We beg our customers to be flexible in using the manual if there is any alteration in structure as a result of technical advancement.

Your opinions about this manual will be valued.

CONTENTS

I.	GENERAL INFORMATION	
	1. ENGINE NUMBER LOCATION	1
	2. BASIC TECHNICAL SPECIFICATIONS	1
	3. DISASSEMBLING AND ASSEMBLING	3
	4. TIGHTENING TORQUE	3
	5. UNIVERSAL AND SPECIAL TOOLS	4
	6. ENGINE FUEL SUPPLY LOCATION	5
	7. TROUBLESHOOTING	6
	8. MAINTENANCE INTERVAL	12
II.	ENGINE DISASSEMBLING, ASSEMBLING, INSPECTION AND ADJUSTMENT	
	1. AIR INLET HOUSING, AIR FOIL	13
	2. CYLINDER HEAD HOOD	13
	3. CYLINDER HEAD AND VALVE	13
	4. CYLINDER AND PISTON	16
	5. KICKSTARTER (INCLUDING LEFT COVER)	18
	6. STEPLESS TRANSMISSION SYSTEM	19
	7. ELECTRIC STARTER	21
	8. MAGNETO AND ELECTRIC FITTINGS (INCLUDING RIGHT CASE COVER)	23
	9. CRANKCASE AND CRANKSHAFT	27
	10. TIMING CHAIN AND TENSIONER	29
	11. LUBRICATION SYSTEM (INCLUDING RIGHT CASE), ENGINE OIL PUMP, FILTER AND FILTER COVER	29
	12. REAR TRANSMISSION SYSTEM	31
	13. CARBURETOR	32
	14. AIR FILTER	35
	ATTACHED PAGES	37

CHAPTER ONE GENERAL INFORMATION

I. ENGINE NUMBER LOCATION

Engine number location is at the lower left front of left crankcase as illustrated in Figure 1:

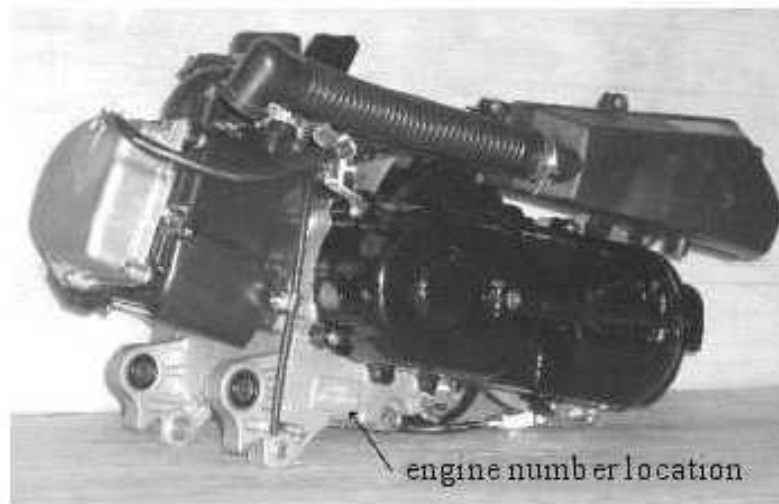

(Figure 1)

II. BASIC TECHNICAL SPECIFICATIONS (See Table 1)

Table 1

Starting mode	Kick starting and electric starting
Type	Four strokes
Number of cylinders	Single
Type of combustion chamber	Hemispheric
Valve structure	O. H. C. chain transmission
Cylinder bore x travel (mm)	39 x 41.4
Total displacement (mL)	49
Compression ratio	10.5
Maximum power (Kw/r/min)	2.2/7500
Maximum torque Nim/r/min	2.9/7000

Valve on-off time	Intake (1mm) vertical	open	0° BTDC	
		closed	25° ABDC	
	Exhaust (1mm) vertical	open	33° ABDC	
		closed	2° BTDC	
Valve gap		intake	0.06	
(Cold state) mm		exhaust	0.08	
Idle speed (r/min)			1900	
Lubrication device	Lubrication mode		Both pressure and splash	
	Oil pump		Internal external rotors	
	Oil filter		strainer	
	Lubricant volume		0.9L	
Cooling mode			Forced air cooling	
Air filter			Sponge strainer	
carburetor	type		Diaphragm carburetor	
	plunger diameter (mm)		Ø16	
	venturi (mm)		16.5	
	throttle		Butterfly valve	
Ignition device	type		CDImagneto ignition	
	ignition time		13° (1700r/min)~28° (3800r/min)	
	breaker		Contactless	
	Spark plug		A7RTC, A7RC CR7HSA (NGK) CR6HSA (NGK)	
Spark plug gap			0.6~0.7 (mm)	
Drive transmission	clutchtype	type	Multiblock dry type	
	transmission	type	Stepless	
		operation	Automatic centrifugal	
	Speed reducer	type		Two-stage reduction
		Reduction ratio	First stage	3.25
			Second stage	3.4

III. PRECAUTIONS IN DISASSEMBLING AND ASSEMBLING

1. Paper pad, rubber seals such as O-ring, ring clip and elastic retainer must be replaced after disassembling.
2. When tightening bolts and nuts, tighten those of larger outside diameter before tightening those of smaller outside diameter; lock them in the order of diagonal lines at specified torques.
3. Use parts and greases produced by regular factories.
4. Special tools or universal tools must be used in disassembling or assembling.
5. After disassembling, parts must be inspected and cleaned and their friction faces lubricated before assembling.
6. The specified lubrication locations must be lubricated with specified lubricants.
7. After assembling parts, confirm the state of locking or movement.
8. When two people are at work, make sure that both are in safety in repair work.
9. When dismounting and mounting battery, the (-) terminal must be disconnected first.
10. When using an open end wrench, prevent slippage so as to prevent injury.
11. At the completion of work, confirm contacting points, fixing points and passages.
12. When connecting battery wires, connect the (+) terminal first.
13. At the completion of battery terminal connection, apply grease to both terminals.
14. When dismounting connectors, press down lock before pulling wire.
15. When pulling connectors, hold connectors in hand instead of pulling wires only.
16. Repair connectors when their terminals are bent, protruding or disconnected.
17. When connector terminals are rusty, rub off rust before connecting them.

III. TIGHTENING TORQUE VALUE

STANDARD TORQUE VALUE

REFER TO STANDARD TORQUE VALUE. See Table 2.

Table 2

Designation	Tightening torque N.m
5mm bolt nut	4.5~0.6
6mm bolt nut	8~12
8mm bolt nut	18~20
10mm bolt nut	30~40
12mm bolt nut	40~50
5mm screw	3.5~5
6mm screw SH bolt	7~11
6mm flange bolt nut	11~14
8mm flange bolt nut	20~30
10mm flange bot nut	35~45

Torque Values of Important Parts of Engine See Table 3.

Table 3

Serial number	Tightening part	Quantity	Screw diameter (mm)	Tightening torque N.m
1	Cylinder head bolt A	2	7	9
2	Cylinder head bolt B	2	7	9
3	Engine oil strainer cover	1	30	15
4	Exhaust pipe connector fixing bolt	2	6	9
5	Camshaft seat flange nut	4	7	16~18
6	Valve adjusting screw	2	5	9
7	Chain stretching plate bolt	1	6	10
8	Oil drain bolt	2	8	10~12
9	Clutch outer disc setscrew nut	1	10	40
10	Magneto rotor setscrew nut	1	10	40
11	Left crankshaft nut	1	12	55
12	Spark plug	1	10	12
13	Engine oil pump driven gear nut	1	6	10
14	Chain tensioner bolt MS*8	1	8	6
15	Rear transmission assembly bolt	7	8	20~22
16	Brake shoe fitting shaft nut	1	8	10
17	Cylinder head cover vent chamber cover screw	4	4	3~5

V. TOOLS (See attached pages for figures)

Table 4

Designation of special tools	Tool number
Flywheel remover	Z01
Valve adjusting fixed wrench	Z02
Spark plug special socket	Z03

Universal Tools

Table 5

Serial number	Designation of universal tools	Tool number
1	fixing bracket	Y01
2	T-sleeve "T" 8 ^ø , 10 ^ø , 12 ^ø , 14 ^ø , 17 ^ø	TS, T10, T12, T14, T17
3	Box-end wrench 9 ^ø	Y02
4	Inner-hexagon wrench 8 ^ø	Y03
5	Shovel	Y04
6	"+" screw driver	Y05
7	Rubber mallet	Y06
8	Sharp-nose pliers	Y07
9	Clip ring caliper	Y08
10	Ratchet wheel wrench	Y09
11	sleeves: 14 ^ø , 17 ^ø	YT14, YT17
12	Internal thread head M6×1; M7×1.25	YM6, YM7
13	Button-head screw driver	Y10

ENGINE OIL SUPPLY LOCATIONS See Table 6

Table 6

Oil supply location	Designation
Valve guide, valve rod flexible part Camshaft cam Valve swing arm friction face Camshaft drive chain Cylinder fixing bolt nut Piston ambience and ring slot Piston pin ambience Cylinder face Connecting rod, piston pin hole Connecting rod big end Crankshaft R side oil seal Engine oil pump sprocket All the bearings' running positions O-ring face Oil seal lip	SAE15-40
Oil seal lip	
Starting wheel gear Starting wheel intermediate gear Starting shaft sleever Starting shaft flexible part Starting one-way clutch	Grease

TROUBLE FINDING

1. Difficult Starting or Refusal to Starting

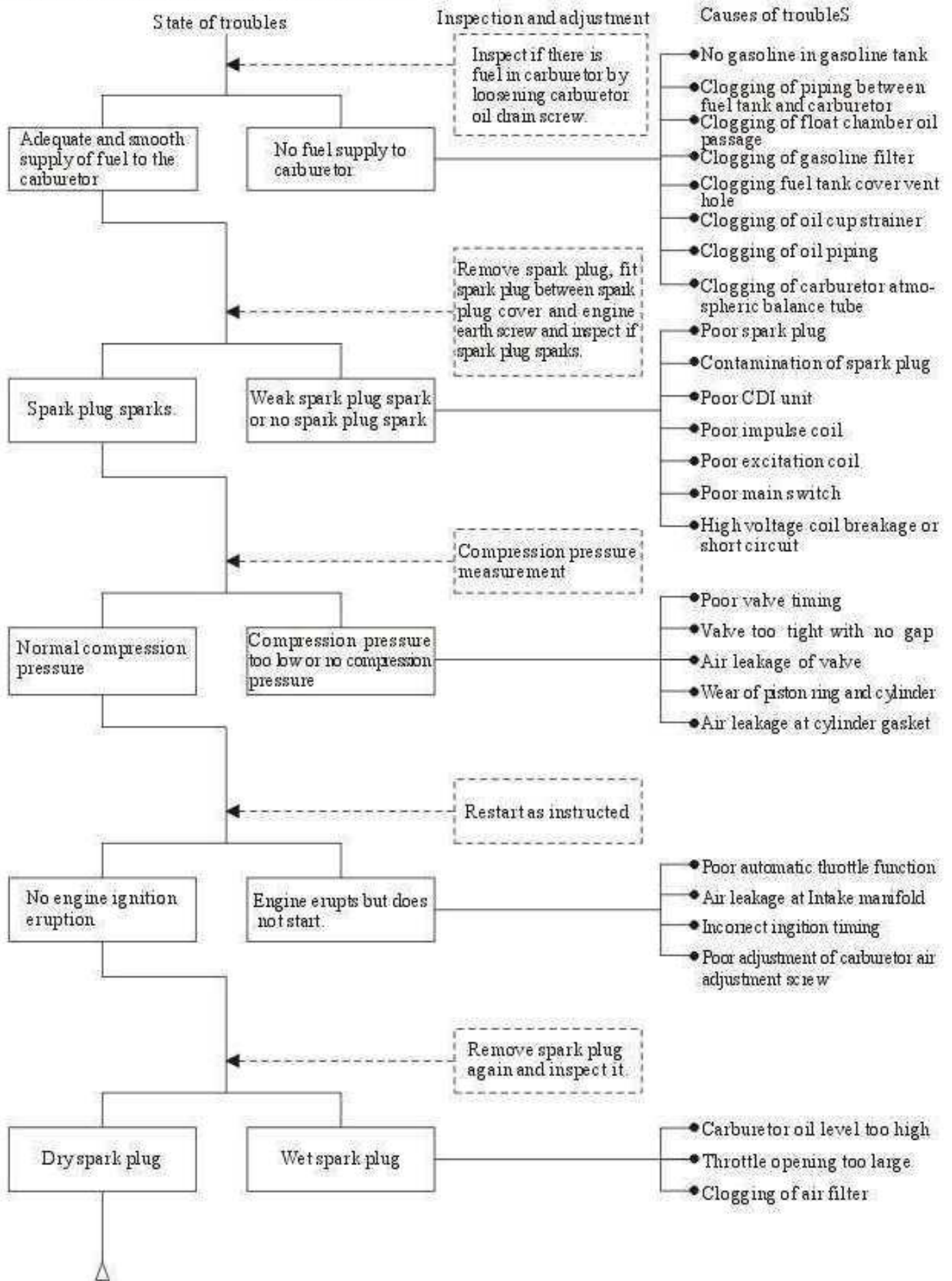

1. Difficult Rotation (Poor Acceleration or Feeble Rotation)

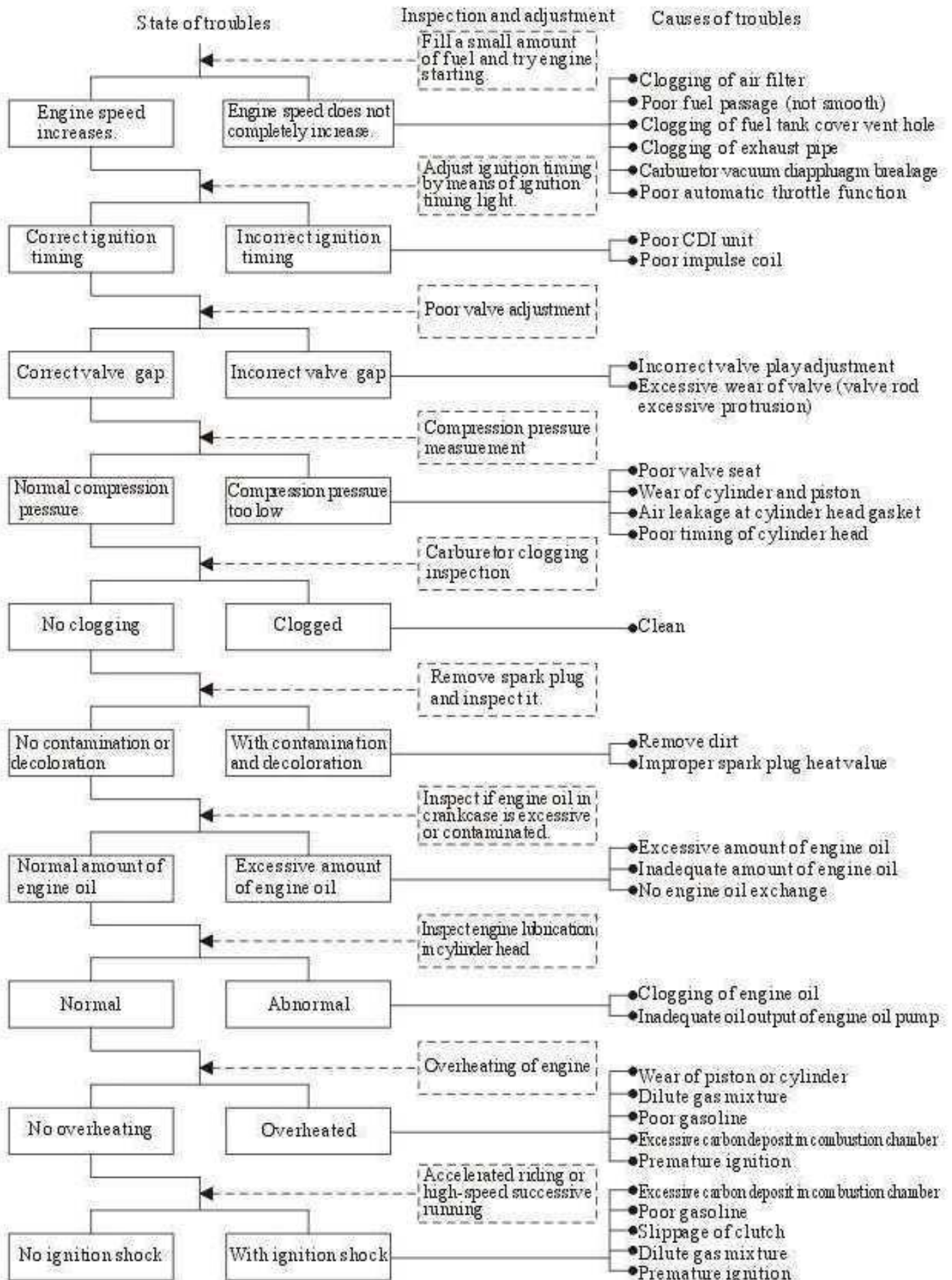

Difficult Rotation (High Speed)

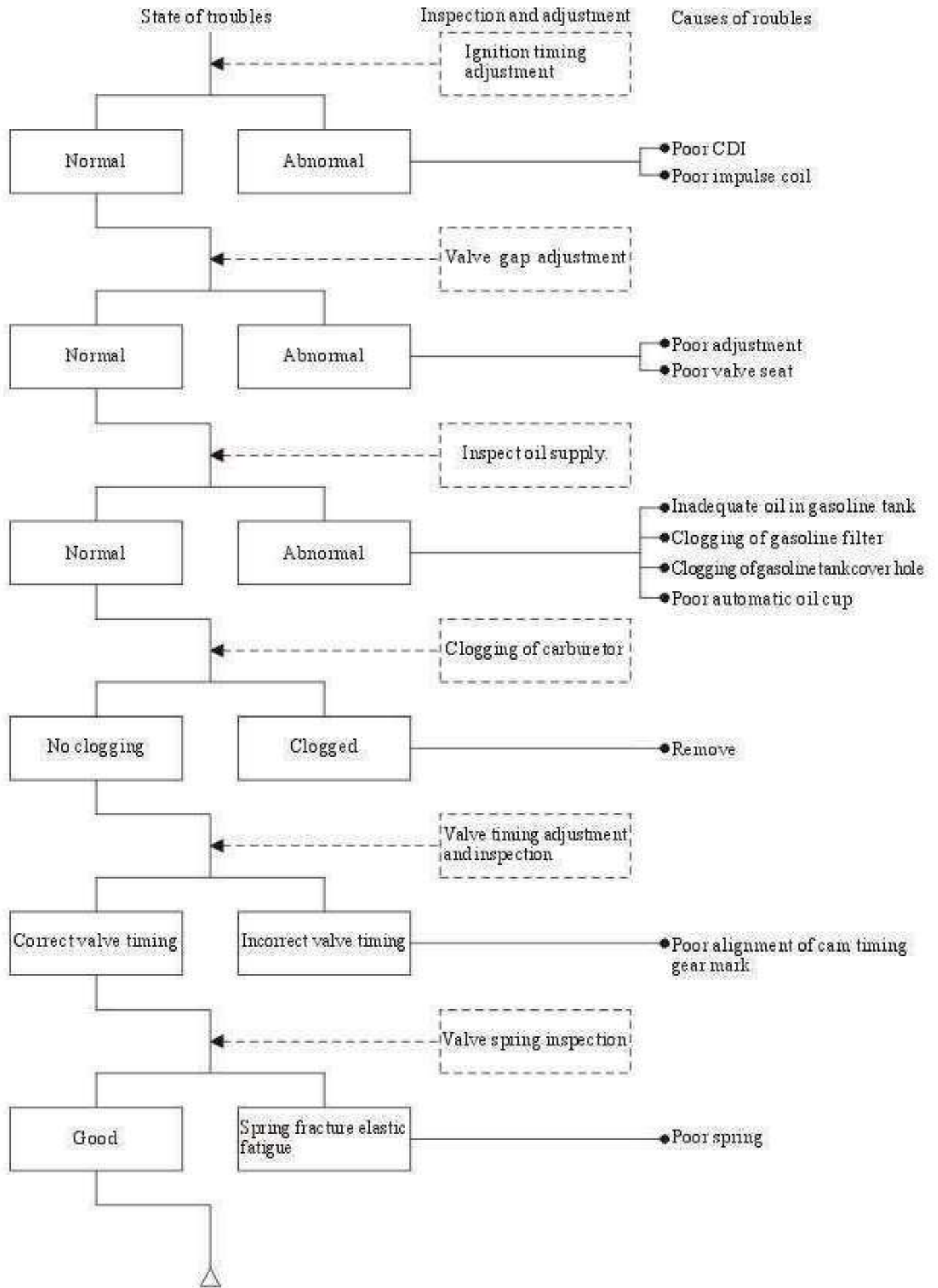

Improper Charging of Battery (Overcharging or Over-discharging)

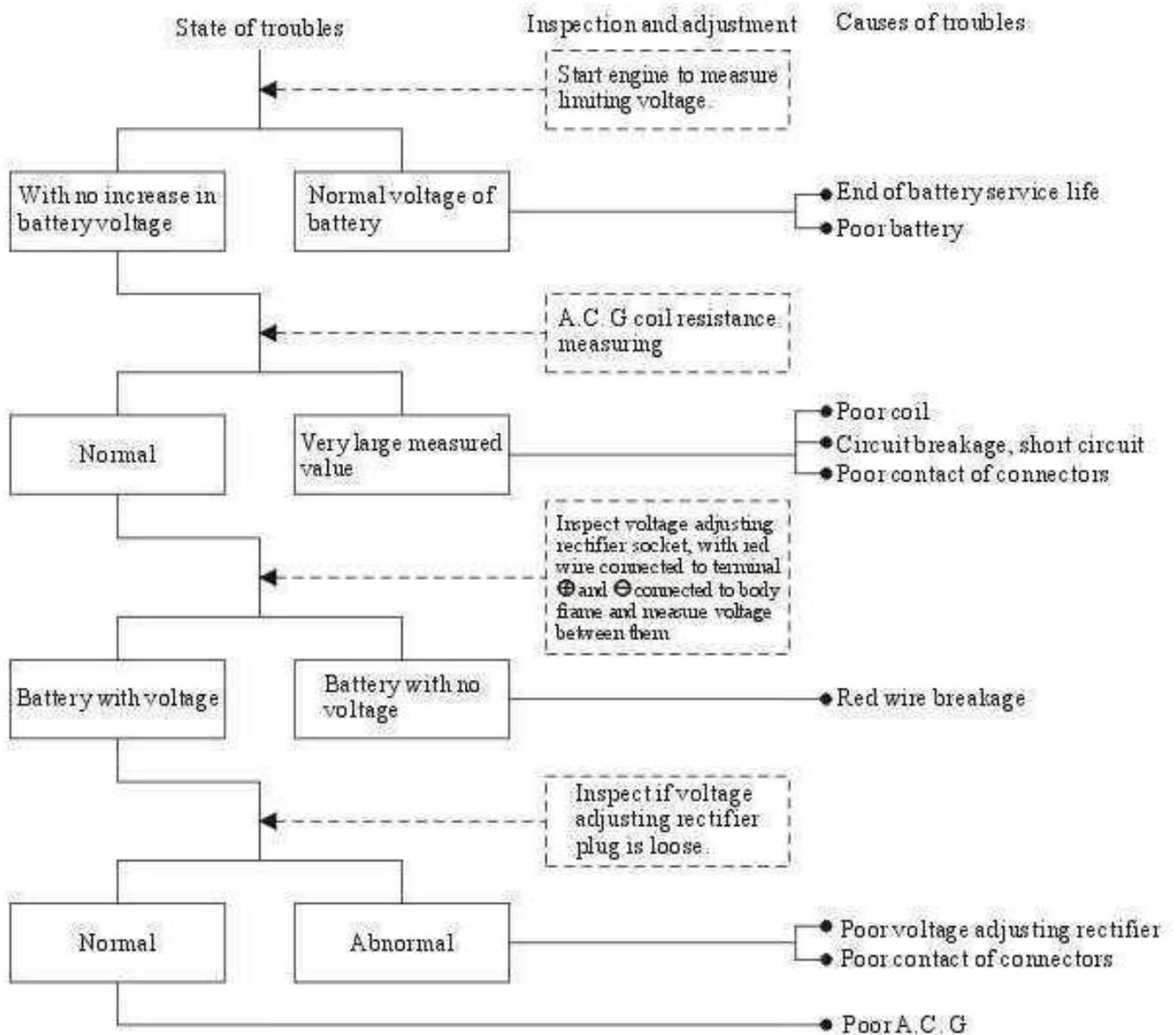

Improper charging (overcharging)

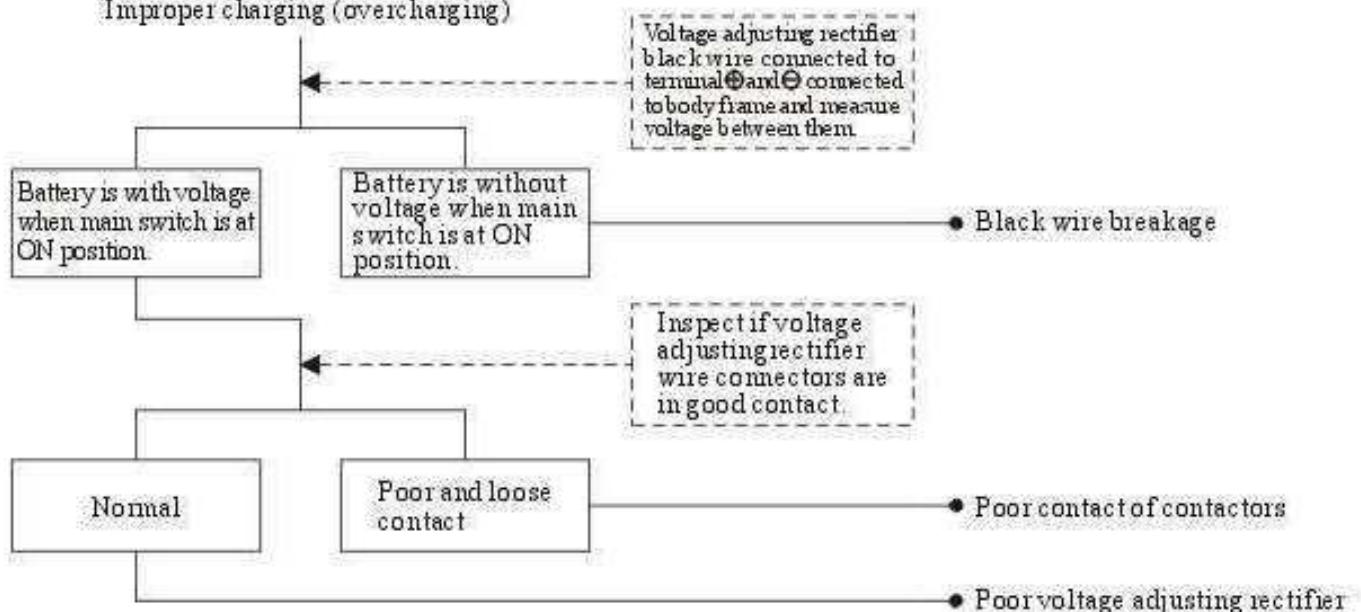

Spark Plug Does Not Spark

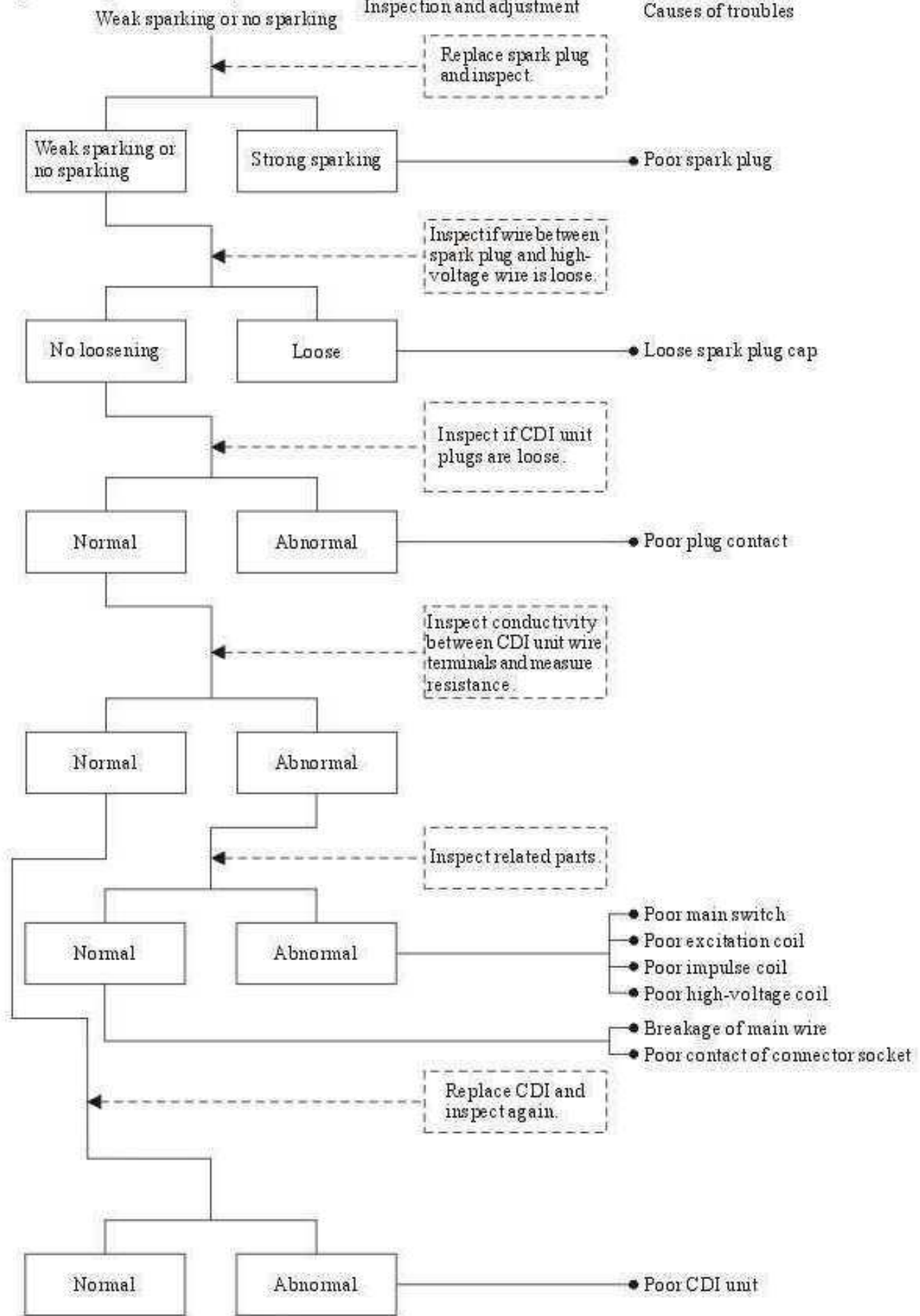

Difficult Rotation (Low Speed and Idle Speed)

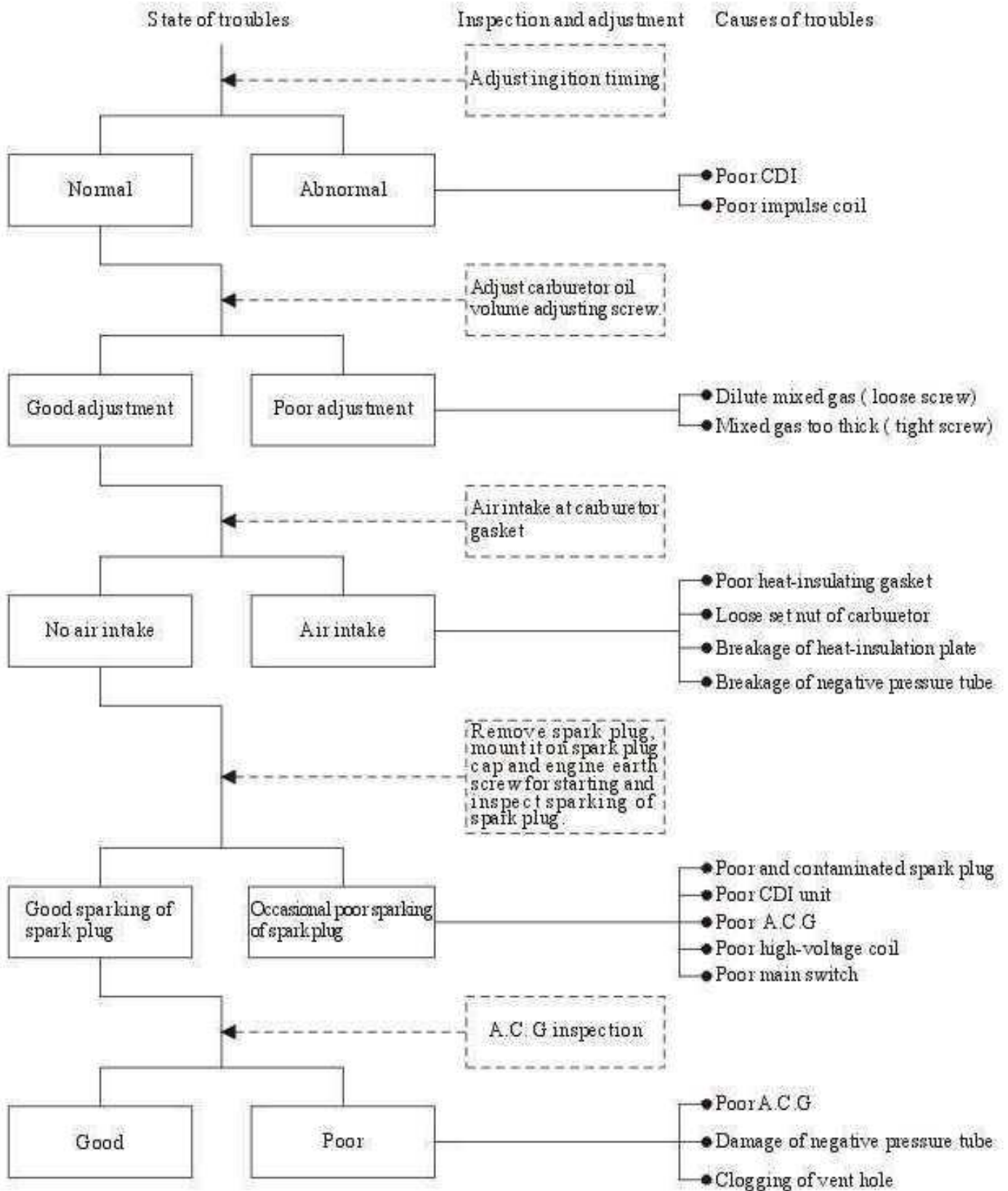

MAINTENANCE INTERVALS

Engine maintenance intervals are recorded in terms of mileage as is illustrated in table 7.
 I: Inspection, Effect cleaning, lubrication, replenishment, modification or replacement when necessary,
 A: Adjustment, C: Cleaning, R: Replacement, T: Tightening

Table 7

Items	Times Note	Mileage Km											
		1000	2000	3000	4000	5000	6000	7000	8000	9000	10000	11000	12000
Engine oil		New vehicle R300	R		R		R		R		R		R
Engine oil strainer					C				C				
Gear oil	Note 3	New vehicle R300				R					R		
Valve gap			A		A				A				A
Carburetor					I				I				C
Air filter	Notes 2, 3	I				C(R)					C(R)		
Spark plug				C(R)			C(R)			C(R)			C(R)
Drive belt									I				
Bolts and nuts									I				
Notes:	1. Please repeat maintenance in case mileage exceeds the specified ranges in the table. 2. Inspection and replacement should be effected in advance in dusty or rainy conditions. 3. Please shorten replacement intervals in heavy-load, long riding or rainy conditions.												

II. ENGINE DISASSEMBLING, ASSEMBLING, INSPECTING AND ADJUSTING

I. Air Inlet Housing and Airfoil Disassembling, Assembling and Inspecting and Adjusting
Remove 2 nuts M6 of carburetor, remove carburetor seat, remove 4 air inlet screws, remove air inlet housing, remove 3 screws M6 of airfoil and clamp, remove airfoil and finally remove airfoil sealing ring from cylinder head. Inspect the parts and in case of dirty parts, clean them to facilitate flow of cooling air. If any part is damaged, replace it. Proceed assembling in a reversed order.

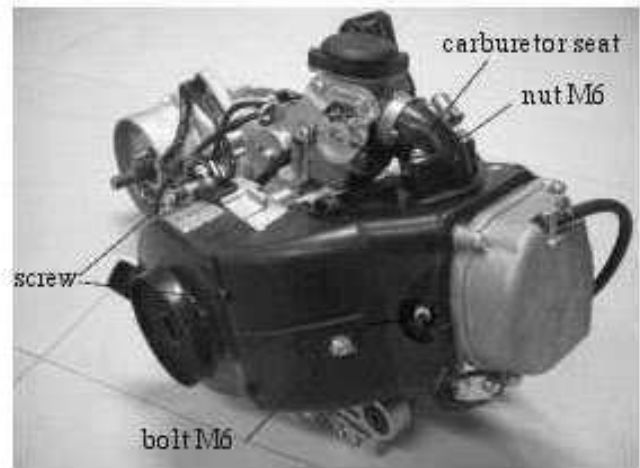

II. Disassembling, Assembling and Inspecting Cylinder Head Hood

Remove 4 bolts M6 of cylinder head hood and clamp, remove cylinder head hood, remove inner and outer oil stains, inspect for easy venting of vent chamber, let in compressed air (Figure 2-1) through exhaust pipe. Quick exhaust of air from vent chamber shows that venting is easy, otherwise it shows that vent chamber is clogged. In case of vent chamber clogging, remove 4 screws M4, dismount parts, clean vent chamber and remove oil stains and clogging matters. After cleaning, mount removed vent chamber parts in their original positions. When mounting, replace vent chamber seal ring and apply sealing adhesive to it. Cylinder hood seal should be replaced when mounting cylinder head hood on engine.

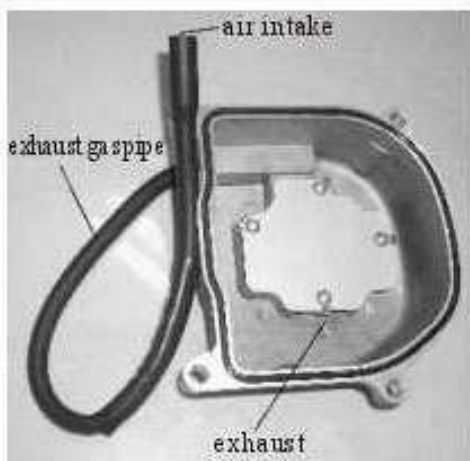

(Figure 2-1)

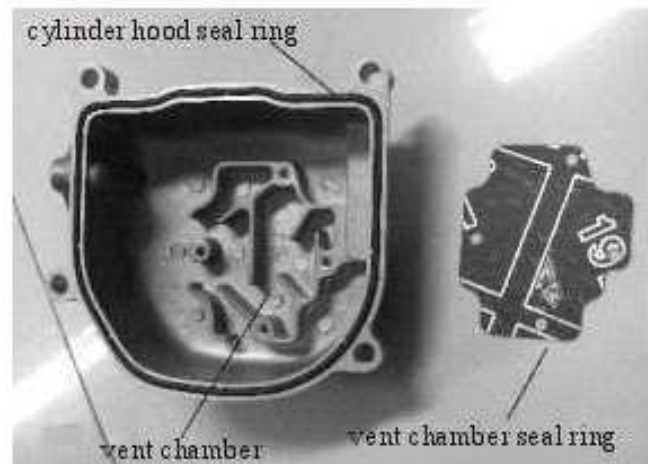

(Figure 2-2)

III. Cylinder Head and Valve

1. Turn plastic fan beside magneto to position a camshaft sprocket hole over it. (Figure 3-1).
2. Loosen tensioner bolt, remove 2 bolts M6x16 of tensioner and remove tensioner and its gasket.
3. Loosen valve gap adjusting screw, remove 4 nuts M7 of cylinder head, remove camshaft mounting seat, remove positioning pin and camshaft.

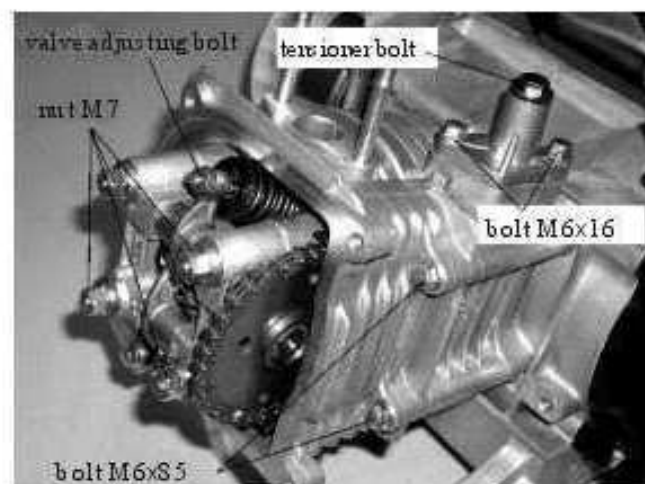

(Figure 3-1)

4. Remove 2 bolts M6x85 of cylinder head, remove cylinder head and cylinder gasket and remove positioning pin from cylinder head.

5. Remove spark plug and carburetor seat insulation gasket. Remove carbon deposit on cylinder head, remove the covering material of cylinder head gasket (Figure 3-2) without harming cylinder head. Remove valve trip by means of valve spring compressor, take out valve spring, spring seat, valve rod oil seal and valve.

6. Inspecting cylinder head: Inspect if there is a fissure near spark plug hole or valve hole (Figure 3-2) and, in case of fissure, replace cylinder head. Inspect valve bushing inner hole, standard value: $5.0 \sim 5.012$, limit of use: replace when it is >5.03 . Inspect if wear of camshaft bearing mounting hole is serious (Figure 3-3) and, if yes, repair or replace it.

7. Inspecting valve spring: Inspect valve inner and outer spring free length (Figure 3-4): Inner spring standard value: 30.5 ± 0.2 , if $L < 28.5$, replace it; outer spring standard value: 34.1 ± 0.2 , if $L < 32$, replace it.

8. Inspecting valve: Inspect if there is any deformation, burn, or damage in intake valve or exhaust valve and if there is eccentric wear in valve rod. In any of the above-mentioned cases, correction or replacement must be effected. Place valve into valve bushing and inspect if it is smooth in movement. Measure air intake valve rod and exhaust valve rod diameters (Figure 3-5), standard value: air intake valve $\phi 4.975 \sim 4.99$, exhaust valve $\phi 4.955 \sim 4.97$, limit of use: replace if air intake valve $d < 4.92$, replace if exhaust valve $d < 4.9$

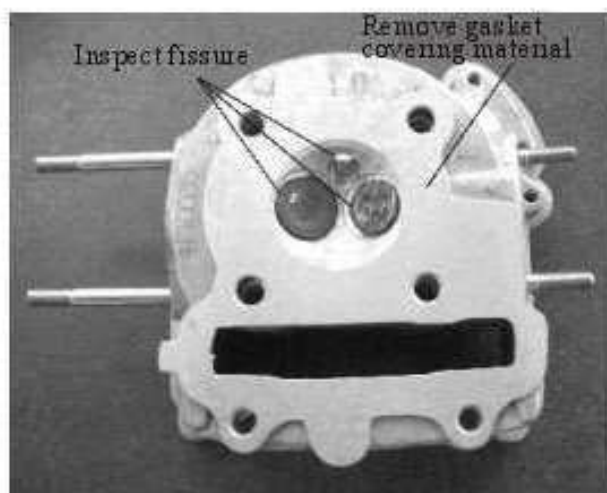

(Figure 3-2)

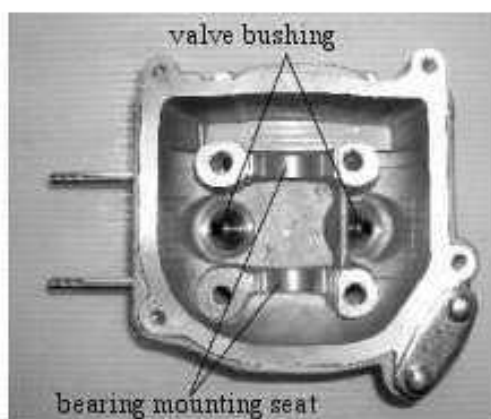

(Figure 3-3)

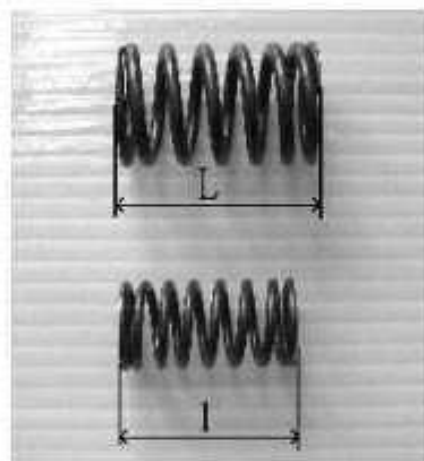

(Figure 3-4)

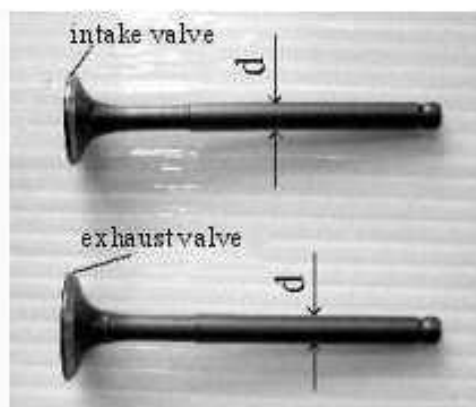

(Figure 3-5)

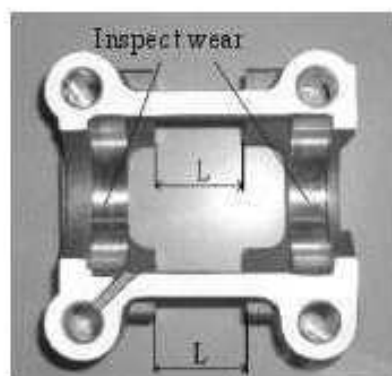

(Figure 3-6)

9. Inspecting spark plug: Remove spark plug carbon deposit and inspect electrode gap. Play should be 0.6~0.7mm.
10. Inspecting camshaft mounting seat: Remove camshaft and swing arm, inspect if wear of bearing mounting hole is serious. If yes, effect correction or replacement. (Figure 3-6)
11. Inspecting air intake and exhaust valves swing arm: Inspect standard value of outside diameter of intake and exhaust swing arm shaft: $\phi 9.937 \sim \phi 9.972$, limit of use: If $d < \phi 9.91$, effect replacement and inspect for free oil passage of intake swing arm. (Figure 3-7)

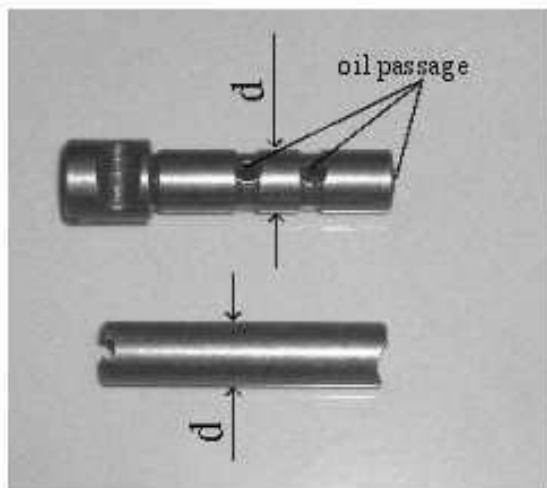

(Figure 3-7)

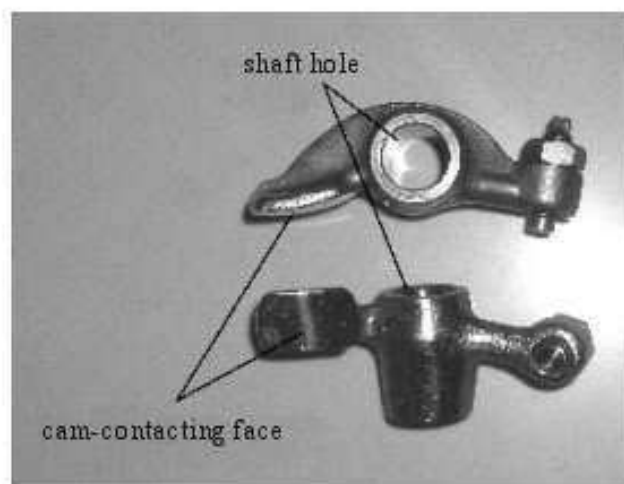

(Figure 3-8)

12. Swing arm inspecting: Inspect wear of swing arm face which contacts cam, inspect wear of swing arm shaft hole, standard value: $\phi 10.022$; limit of use: if $> \phi 10.1$, effect replacement (Figure 3-8)
13. Valve camshaft assembly: Inspect maneuverability of valve camshaft bearing, inspect wear of timing chain sprocket wheel and inspect heights of intake cam and exhaust cam. Intake cam height standard value: 25.745mm; exhaust cam height standard value: 25.55mm; limit of use: if that of intake cam < 25.345 mm, effect replacement and if that of exhaust cam < 25.15 mm, effect replacement.

Assemble inspected or corrected parts in an order reversed to that of disassembling as specified, paying attention to the following points:

1. Apply seal adhesive to the two sides of tensioner paper gasket, torque bolt M8x8. 6N.m,
2. Mount camshaft on cylinder head with camshaft intake and exit cam downward, make the two small hole reticles parallel to cylinder head face with the larger hole perpendicular to cylinder (Figure 3-10); align mark reticle "T" on fly wheel with aligning mark on right crankcase cover (Figure 3-11).



(Figure 3-9)

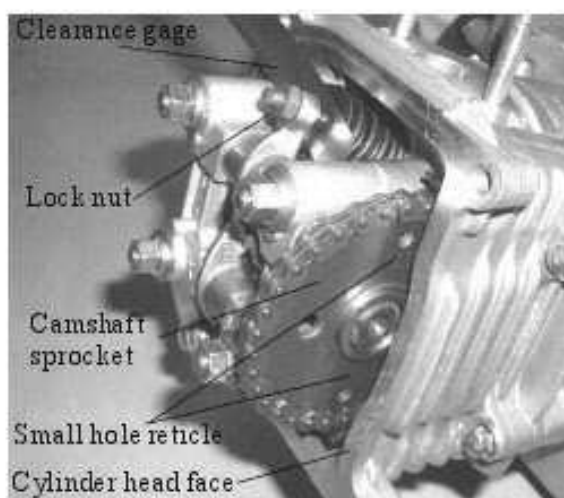

(Figure 3-10)

3. Tighten cylinder head nut M7 in 2~3 steps at a torque of 16-18N.m;
4. Valve gap adjusting: Intake valve 0.06mm, exhaust valve: 0.08mm, valve adjusting screw lock nut torque: 9N.m (Figure 3-10)

IV. Disassembling And Inspecting Cylinder Block and Piston

1. Take out guide board, remove cylinder block and positioning pin.
2. Remove piston pin retaining ring with button-head screw driver, remove piston pin and piston (Figure 4-1).

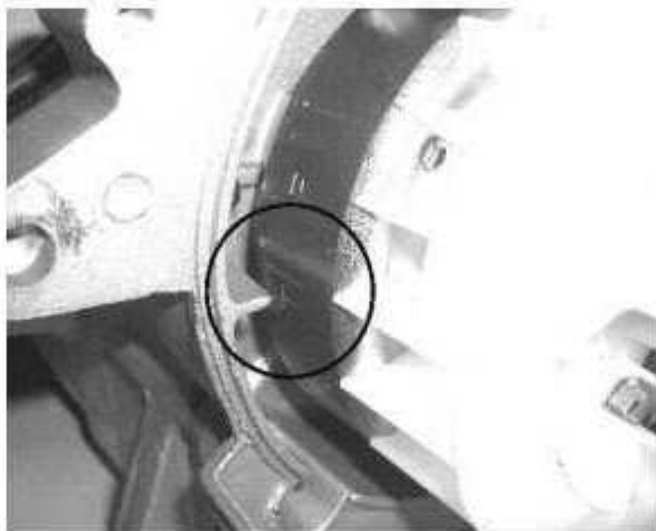

(Figure 3-11)

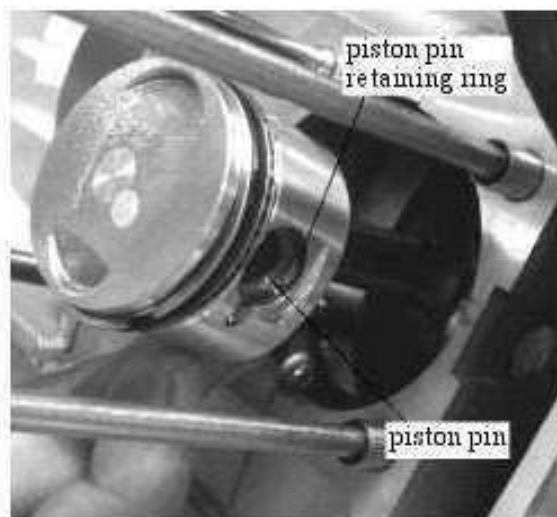

(Figure 4-1)

3. Remove gasket material on cylinder block with a shovel, remove carbon deposit in cylinder sleeve (Figure 4-2) and inspect wear in cylinder sleeve.
4. Remove carbon deposit on top of piston, inspect and measure wear of piston skirt (Figure 4-3), standard value: 38.99~38.97, limit of use: if <38.93, effect replacement.

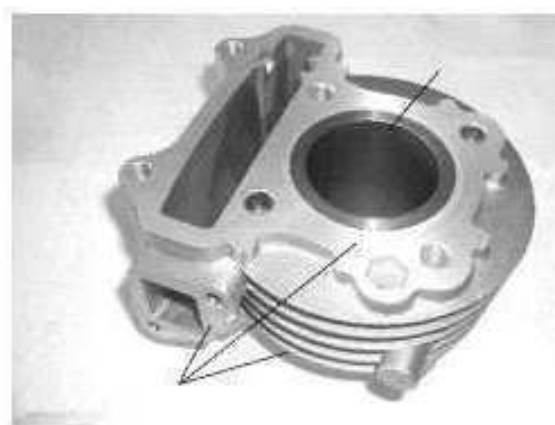

(Figure 4-2)

5. Measure cylinder bore diameter at 3 positions in a rectangular direction (X-Y), standard value: $\varnothing 39.0 \sim \varnothing 39.01$ mm (Figure 4-4) (Figure 4-5). Limit of cylinder use: if $> \varnothing 39.1$ mm, effect replacement. If play between cylinder and piston exceeds 0.10, effect correction or replacement.



(Figure 4-3)



(Figure 4-5)

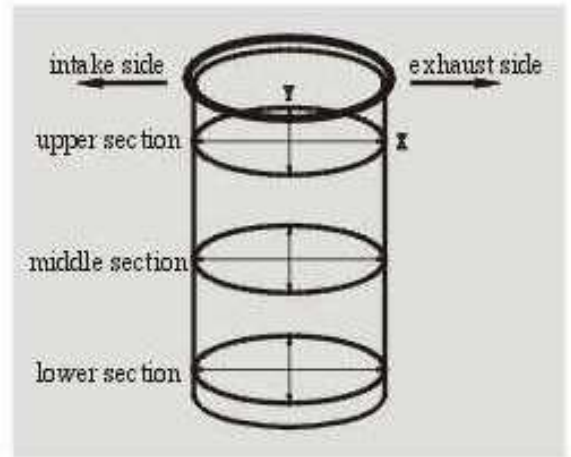

(Figure 4-4)



(Figure 4-6)

6. Inspect and measure outside diameter of piston pin (Figure 4-6), standard value: $\phi 12.998 \sim \phi 12.992\text{mm}$, limit of use: if $< \phi 12.97\text{mm}$, effect replaceme
7. Inspect and measure inside diameter of piston pin hole (Figure 4-7), standard value: $\phi 13.002 \sim \phi 13.008$, limit of use: if $> \phi 13.04$, effect replacement.
8. Inspect mating gap between piston pin hole and pin, limit of use: if $> 0.04\text{mm}$, effect replacement.
9. Inspect wear of piston ring and groove (Figure 4-8). Thickness of first piston ring $0.77 \sim 0.79\text{mm}$, of second piston ring $0.795 \sim 0.775\text{mm}$, width of piston groove 0.82mm , limit of use: if first and second ring width $> 0.72\text{mm}$, effect replacement
10. Remove piston ring (Figure 4-9), mount piston rings to the lower part of cylinder and measure piston ring end gap (Figure 4-10). First piston ring assembly gap $0.08 \sim 0.20\text{mm}$, second piston ring assembly gap $0.05 \sim 0.20\text{mm}$. Limit of use: if $> 0.5\text{mm}$ for first and second, effect replacement.



(Figure 4-7)

11. Mount inspected or corrected parts in an order reversed to that of disassembling as specified. In mounting, piston rings should be 90° or 120° in relative positions (Figure 4-11). Mount pistons, the side marked "IN" should face intake side.

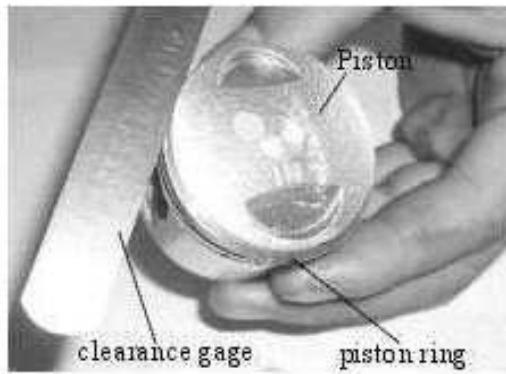

(Figure 4-8)



(Figure 4-9)

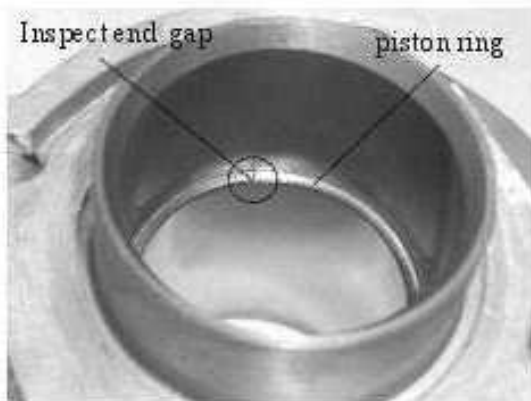

(Figure 4-10)



(Figure 4-11)

Kickstarter Disassembling and Inspecting

1. Remove 8 bolts M6x35 of left camshaft cover, wire clip assembly, rear brake wire assembly, kick rod screw M6x25 and left cover.
2. Press kick starting rod, remove foot-operated intermediate gear, remove kick starting rod, remove retaining ring by means of clip ring calipers (Figure 5-1) and remove starting shaft assembly and return spring (Figure 5-2).



(Figure 5-1)

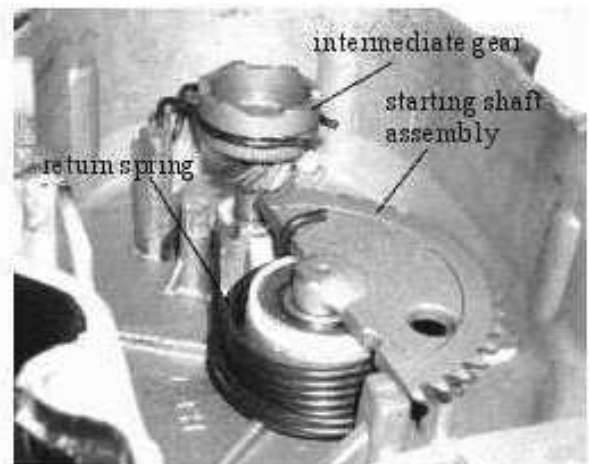

(Figure 5-2)

- 3 Remove rust on starting shaft gear and foot-operated intermediate gear, inspect if there is any damage due to impact, wear or other damage and correct it in case there is.
- 4 Inspect returning elasticity of return spring. Replace it if elasticity is weak.
- 5 Mount inspected or corrected parts in an order reversed to that of disassembling.

Note: A. Apply a small amount of grease or molybdc sulfide to inside and outside of starting shaft and gear.
 B. Inspect that kick starting rod actuates starting shaft smoothly and that intermediate gear moves up and down.
 C. Axial jerky motion gap < 1mm when starting shaft assembly is mounted in left cover.

VI. Disassembling and Inspecting Stepless Transmission System

1. Fix main drive gear by means of fixing clamp, remove nut M13 washer, drive gear left part, fan, foot-operated driven claw (Figure 6-1).

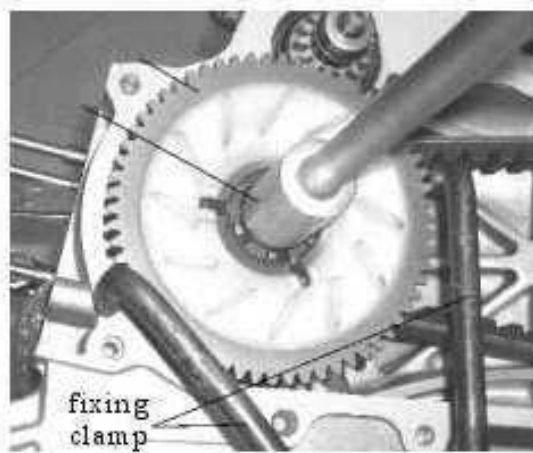

(Figure 6-1)

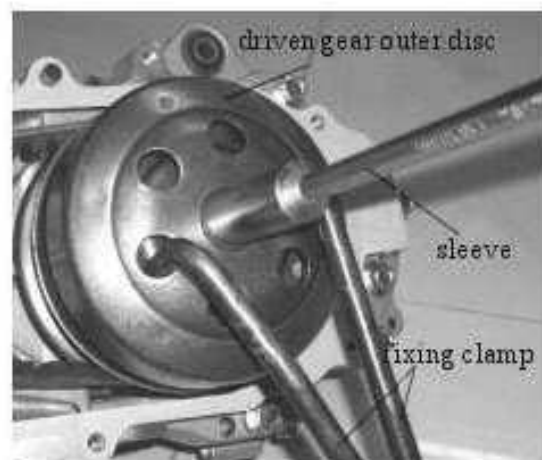

(Figure 6-2)

2. Fix driven gear outer disc by means of fixing clamp, remove nut M10, driven gear and V-belt (Figure 6-2).
3. Remove right part of drive gear and shaft sleeve (Figure 6-3).
4. Inspect if centrifugal roller is damaged or worn, outside diameter standard value: $\phi 16 \pm 0.08\text{mm}$ (Figure 6-4), limit of use: if $D < 15.5\text{mm}$, effect replacement.
5. Inspect bore diameter of central hole on the right of drive gear, standard value: $\phi 20.009 \sim \phi 20.027\text{mm}$, limit of use: if $> \phi 20.06\text{mm}$, effect replacement.
6. Inspect if drive gear sleeve is worn or damaged and measure its outside diameter. Standard value: $\phi 19.995 \sim \phi 19.98\text{mm}$, if $< 19.94\text{mm}$, effect replacement.

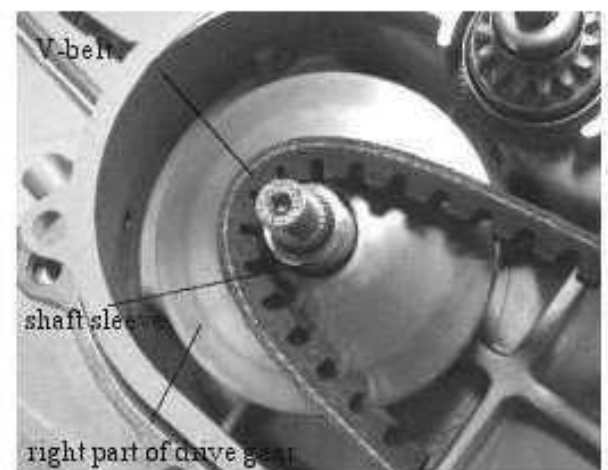

(Figure 6-3)

7. Inspect if drive face on the right of drive gear is worn or damaged (Figure 6-5). Limit of use: if $>0.4\text{mm}$, effect replacement.
8. Inspect if driven gear outside disc is worn or damaged and measure its diameter. (Figure 6-6). Standard value: $\varnothing 107.0 \sim \varnothing 107.2\text{mm}$, limit of use: if $D > 107.5\text{mm}$, effect replacement.
9. Inspect if driven gear centrifugal friction pad is worn or damaged (Figure 6-7). Limit of use: if friction pad $< 2.0\text{mm}$, effect replacement.

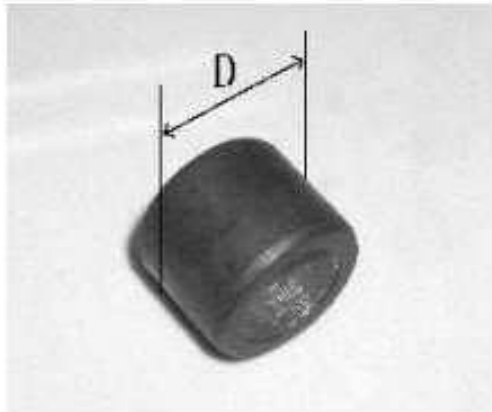

(Figure 6-4)

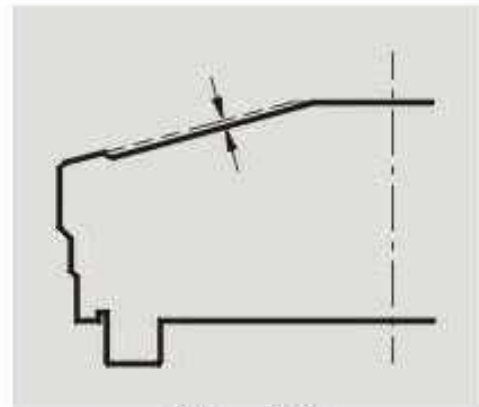

(Figure 6-5)



(Figure 6-6)



(Figure 6-7)

10. Inspect wear depth of driven gear driven face and moving driven face (Figure 6-8), limit of use: if $>0.4\text{mm}$, effect replacement.
11. Inspect to ascertain easy rotation, jamming, wear or damage of roller bearing and needle bearing of driven gear, remove ashes and dirt and apply grease to bearings (Figure 6-7) (Figure 6-9).

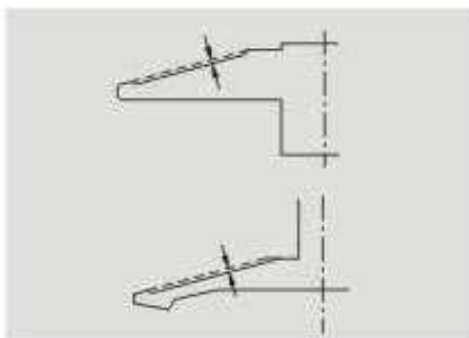

(Figure 6-8)

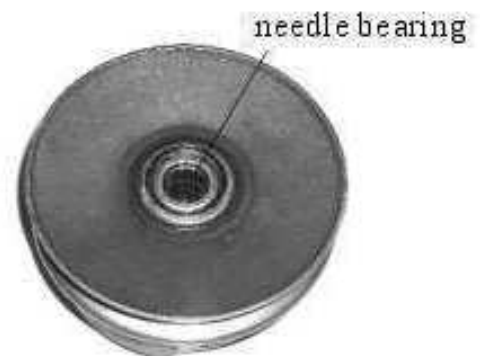

(Figure 6-9)

12. Inspect if there is any wear of V-belt. Measure belt working face (Figure 6-10), standard value: $18 \pm 0.3\text{mm}$, limit of use if $<16\text{mm}$, effect replacement.

13. Inspect wear of foot-operated drive claw teeth and effect replacement in case of serious wear. Mount inspected or corrected parts in an order reversed to that of dismantling as technically specified.

Note: A Do not let grease adhere to V-belt, drive gear or driven gear sliding faces.

B Tighten nut only after ascertaining that drive gear does not press V-belt.

C Camshaft left nut M12 torque: 55N.m.

D Input shaft nut M10 torque: 40N.m.

VII. Electric Starter

Electric starter consists of starting motor, starting relay and one-way clutch and belt drive gear left part.

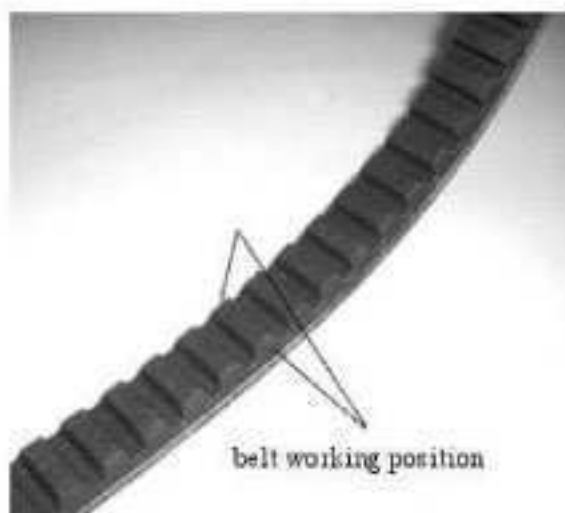

(Figure 6-10)



(Figure 7-1)



(Figure 7-2)

1. Starting System Diagram (Figure 7-1) (Figure 7-2)

2. Precautions:

- Starting motor dismantling can be effected on the motorcycle
- One-way clutch assembly can be dismantled after removing left cover. (Figure 7-3)
- Ensure correct electric connection when mounting starting circuit so as to prevent difficult starting due to poor contact.

3. Troubles Finding

A. Unable to start

- breakage of fuse
- insufficient charging of battery
- poor main switch
- poor one-way clutch
- poor connection of wires
- poor starting motor

B. Weak power of starting motor

- inadequate charging of battery



(Figure 7-3)

- poor connection of wires
- C. Engine does not rotate while starting motor rotates.
- poor one-way clutch
- starting motor rotates in opposite direction (incorrect connection of wires)
- insufficient charge of battery

4. Electric starting system main parts inspection

Electric starting motor can be removed from motorcycle by removing starting motor wire fixer first and then removing 2 bolts M6 (Figure 7-4).

Precaution: Turn main switch to OFF position first and then actuate starting switch to see if starting motor rotates so as to ascertain safety.

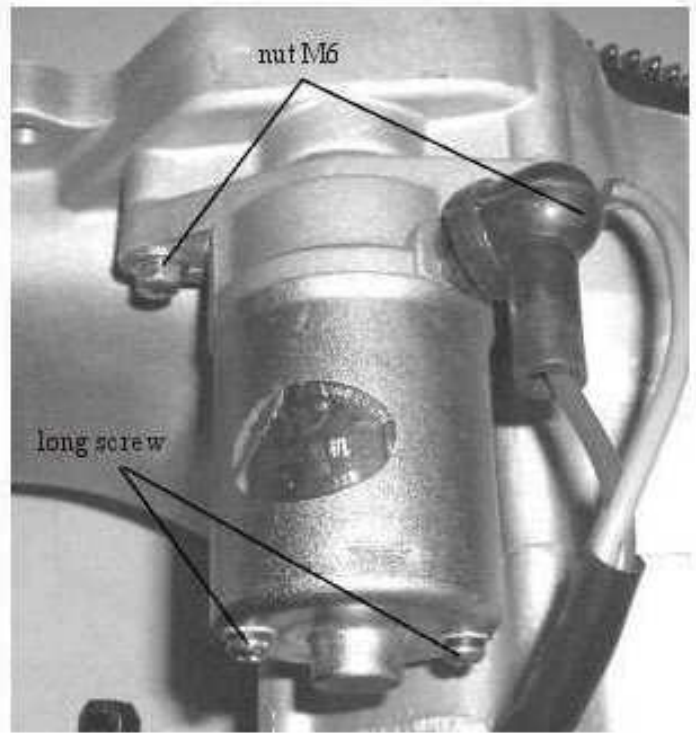

(Figure 7-4)

4.1 Starting motor inspection

- Inspect that there is no conductivity between wire terminals and starting motor outer case.
- Remove 2 long screws to disassemble starting motor and inspect length of electric brush and the condition of surfaces. Effect replacement if necessary.

4.2 Starting relay

Circuit diagram of starting relay: (Figure 7-5)

- Remove the covering part of motorcycle to see starting relay, turn main switch to "ON" position and press starting button till a clicking sound to normalize the condition.

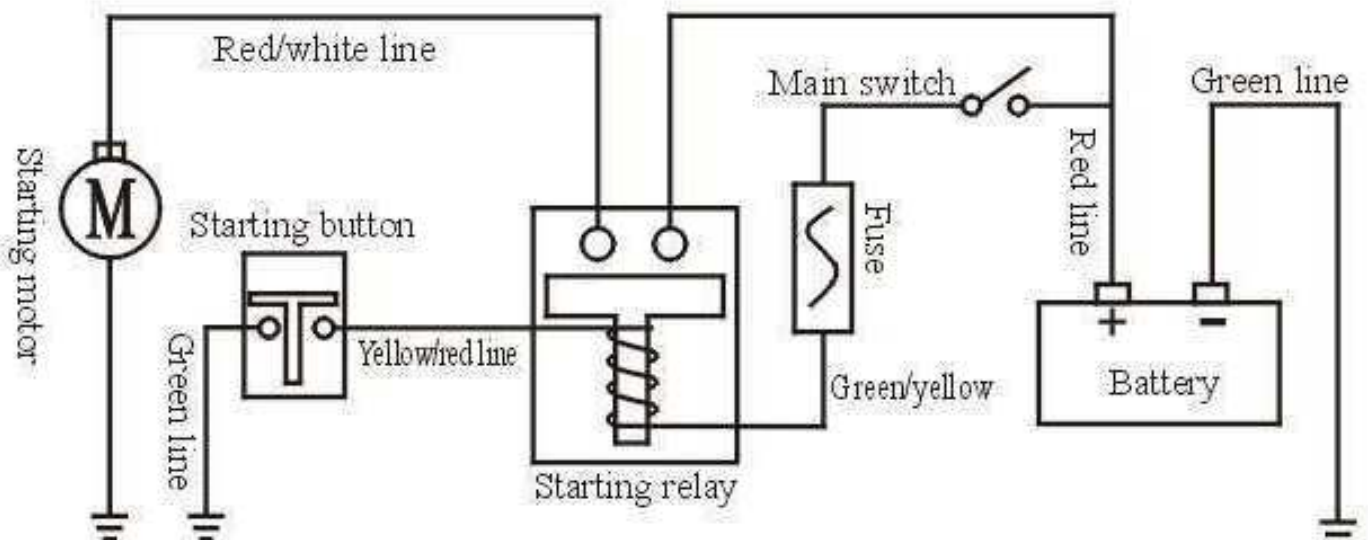

B. When mute

- Inspect starting relay voltage.
- Inspect starting relay earthing return wire.
- Inspect conductivity between starting relay wires.

Connect two wires of starting relay with 12V battery with starting motor terminals connected parallel with circuit tester (Figure 7-6). Conductivity between two terminals indicate normality. Otherwise, effect replacement.

4.3. One-way clutch assembly

One-way clutch is dismountable when engine left cover is removed. (Figure 7-3) Move one-way clutch gear and gear movement is smooth on the shaft without jamming or incomplete return. It is motionless in case of opposite direction. When electric parts and battery voltage are normal, one-way clutch gear should slide out to engage the left of belt drive gear to start engine. In case gear does not slide out, replace one-way clutch assembly.

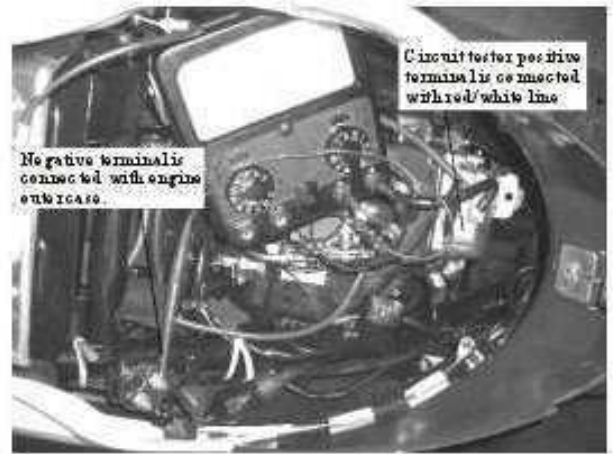

(Figure 7-6)

VIII. MAGNETO AND ELECTRIC PARTS

Magneto disassembling and assembling

1. Remove cooling fan by removing its 4 bolts M6X16 (Figure 8-1).



(Figure 8-1)

2. Fix flywheel with fixing clamp, unscrew nut M10, remove flywheel with special tool. (Figure 9-2)
3. Remove 2 bolts M5X12, 2 bolts M6X22 and magneto coil. (Figure 8-3)
4. Remove right crankcase cover bolt and set pin.
5. Remove paper gasket material and oil deposit at the joint face between right crankcase and right cover.

Mounting should be effected in an order reversed to that of parts dismounting.

Note that the torque of flywheel nut is 40N.m

1. Composition of magneto and electric parts (Figure 8-4)

It consist of magneto (stator coil, flywheel rotor), CDI, ignition coil assembly and rectifier adjustor.

Its mating parts include spark plug, starting relay, starting motor, battery and cables.



(Figure 8-2)

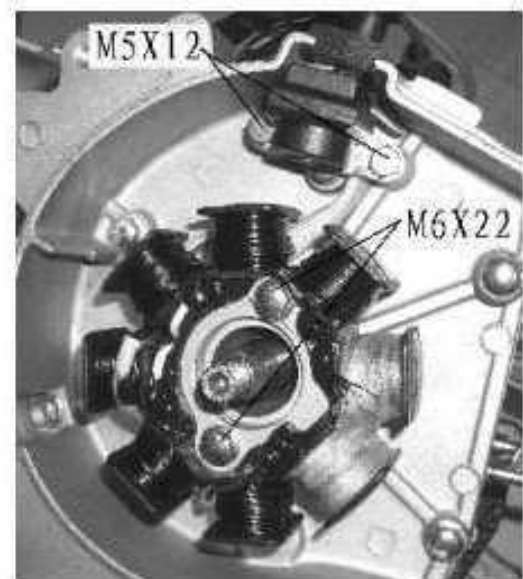

(Figure 8-3)

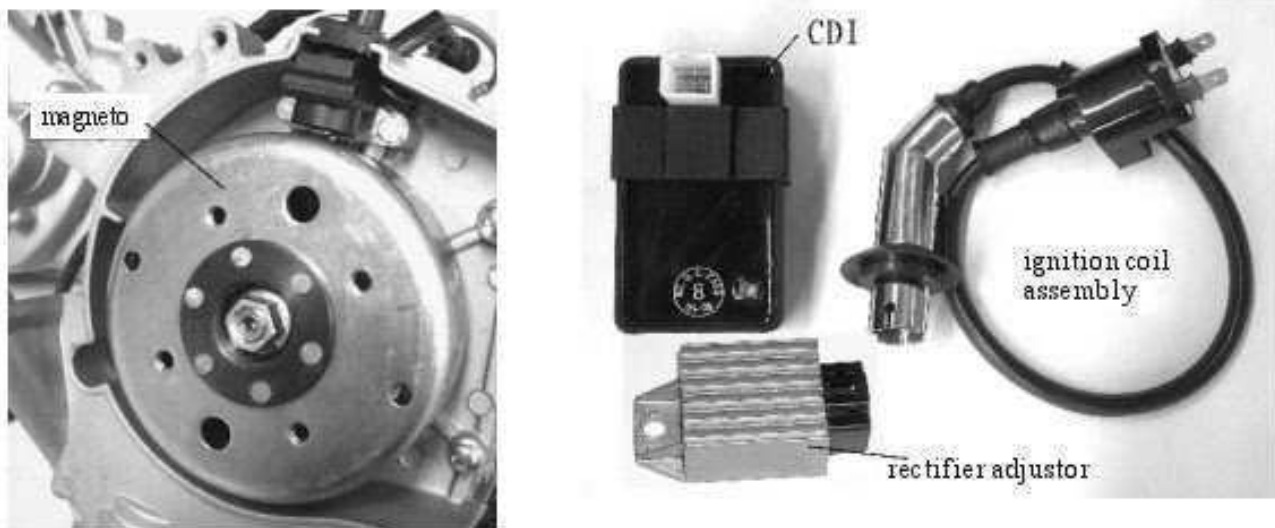

(Figure 8-4)

2. Magneto and electric parts disassembling and assembling

3. Ignition system

Ignition system circuit diagram. (Figure 8-6)

When magneto rotates, excitation coil generates electric current which enters C.D.I. pulse coil to control triggering and electric current is boosted in voltage to effect spark plug sparking.

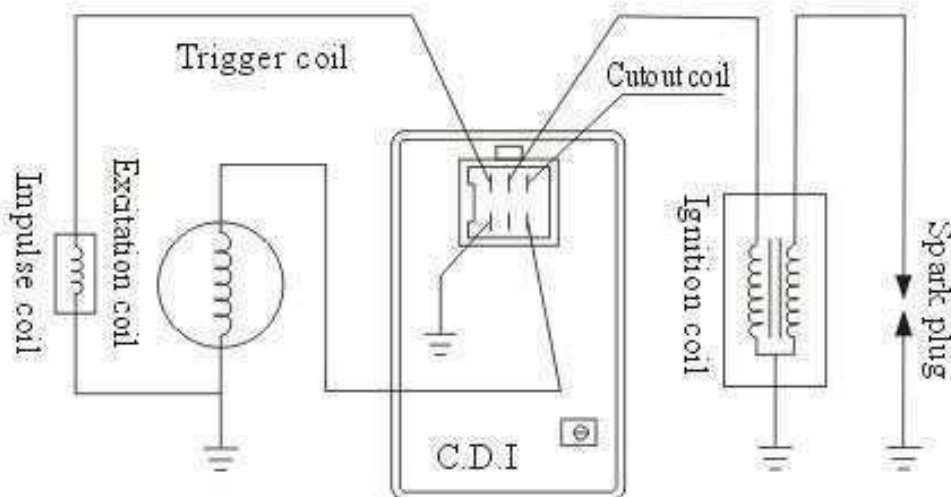

(Figure 8-5)

3.1 Precautions in maintenance

- Inspection of ignition system is effected according to trouble finding specifications.
- This ignition system is a CDI device without necessity of ignition angle adjustment.
- Ignition system can not be dropped out, drooped or impacted. Dismounting should be effected with care.
- In many cases, troubles in ignition system find their causes in poor contact of connector sockets. Before maintenance, inspect if there is any poor contact of connectors.
- Spark plug should be proper in thermal value, which could be altered according to working conditions. Improper thermal value can lead to difficult rotation or burn of engine.

Item		Standard values	
Spark plug	Standard	A7RC、A7RTC、CR7HSA (NGK)	
	Hot type	A6RC、A6RTC、CR6HSA (NGK)	
	Cold type	A8RC、A8RTC、CR8HSA (NGK)	
Spark plug gap		0.6 ~ 0.7 mm	
Ignition time	"F" mark	13° before upper stop (1700r/min)	
	Maximum angle	23° before upper stop (3800r/min)	
High-voltage ignition coil resistance value (20°C)	Primary coil		
	Secondary coil	With plug cap	8 ~ 12K Ω
		Without plug cap	3 ~ 5K Ω
Pulse coil resistance value (20°C)		140 ~ 200 Ω	
Excitation coil resistance value (20°C)		350 ~ 450 Ω	
High-voltage ignition coil maximum voltage		> 112V	
Pulse coil maximum voltage		> 2V	
Excitation coil maximum voltage		> 100V	

3.3 Inspection instrument: circuit tester

3.4 Ignition system trouble finding

A. No spark of spark plug

Poor main switch

Poor, damaged or disconnected connecting wires

Poor spark plug or secondary current leakage

Poor magneto stator coil (pulse excitation)

Poor C. D. I.

B. Engine stops after starting

Poor sparking of spark plug

Improper ignition time

Poor C. D. I.

C. Difficult rotation of engine after starting

Poor ignition coil

Poor spark plug

Spark plug cap electric leakage

Poor magneto

Poor stator coil

Poor C. D. I.

3.5 Ignition system inspecting

A. Measure resistance of high-voltage ignition coil with three-in-one meter

Primary coil resistance resistance value 0.2 ~ 0.3K Ω

Measure secondary coil resistance with plug cap on resistance value 8 ~ 12K Ω

Measure secondary coil resistance with plug cap removed resistance value 3 ~ 5K Ω

B. Spark plug and C. D. I.

It is not easy to inspect spark plug with simple tools. Comparison method is easier.

Compare parts in question with normal parts for evaluation

C. Impulse coil

Measure resistance between blue/white wire and earth wire, resistance value 140~200 Ω

D. Excitation coil

Measure resistance between red/black wire and earth wire, resistance value 350~450 Ω

4. Charge (lighting) system

Charge (lighting) system consists of lighting charge coil of magneto stator coil, rectifier adjuster, battery and wire harness coil.

4.1 Charge (lighting) system circuit diagram for inspection (Figure 3-6)

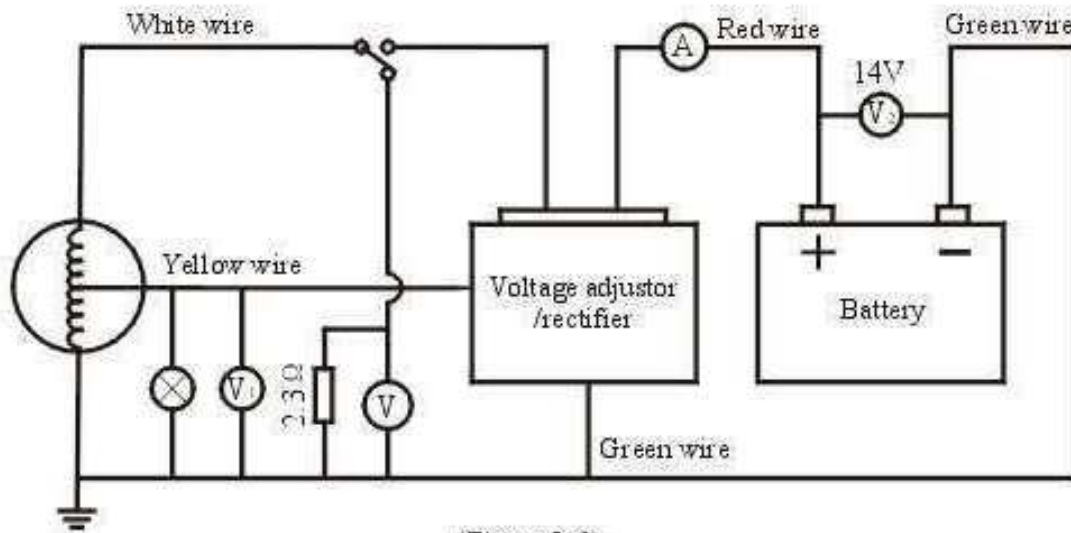

(Figure 3-6)

In the diagram, ○X symbolizes headlight. When headlight is not on during the day, discharge is effected through releasing resistance. V₁ and V₂ symbolize circuit tester for measuring voltage.

4.2 Precautions in maintenance in inspection

- When necessary, distilled water should be added to MF battery (Distilled water must be used for the first time).
- Never use quick charge.
- Remove battery when charging. In case charging is needed with battery on motorcycle, stay away from source of heat or spark.
- When effecting wiring, fix wires properly to avoid short circuit due to wire damage.

4.3 Charging condition inspecting

Inspect battery with battery in safe charging condition.

- Warm up engine for 10 minutes after engine starts.
- Connect battery positive terminal with ammeter negative terminal before connecting ammeter positive terminal with battery positive terminal.
- Connect voltmeter positive terminal with battery positive terminal and voltmeter negative terminal to battery negative terminal.
- Charging performance

Voltage in the following table is white wire voltage measured when connected to 2.3 Ω and the current is the current measured when rectified voltage is 14V.

Lighting wire	Beginning of Charge r/min	3000r/min	3000r/min
White	<2500	16.3V, 4.5A	18.2V, 5A
Yellow	<2500	13.1V	15.1V

E. Limiting voltage

Start engine and measure limiting voltage as speed increases. Limiting voltage $14.5 \pm 0.5V$

Note: Battery is measured when fully charged.

E. Inspect charge (lighting) wire resistance, resistance value $0.1 \sim 0.2 \Omega$

G. Rectifier adjustor

Inspection of rectifier adjuster is to measure resistance between connectors, which is not easy in correct judgment. Comparison between the part in question and confirmed good rectifier adjuster is recommended.

4.4 Trouble finding

A. No power supply

- Battery over-discharging
- No electrolyte in battery

- Improper wire connection
- Poor power supply switch

B. Low voltage

- Inadequate battery charging
- Poor terminal connection
- Poor charging system
- Poor adjustment of adjusting rectifier

C. Interrupted current

- Poor contact of battery wires
- Poor contact of charging system
- Poor contact of light system

D. Poor charging system

- Poor contact of wire terminals, breakage of circuit or short circuit
- Poor adjusting rectifier
- Poor magneto stator coil



(Figure 9-1)

IX Crankcase and Crankshaft

1. Crankcase consists of left crankcase, right crankcase and crankshaft connecting rod.

2. Crankcase and crankshaft disassembling and inspecting:

2.1 Remove crankcase bolt M6x45, place left crankcase discharger below, remove right crankcase, set case, seal gasket and remove crankshaft connecting rod assembly from left crankcase (Figure 9-1).

2.2 Remove case paper gasket and oil deposit, let in compressed air through oil passage hole and inspect if oil passage holes are open and through. (Figure 9-2)

2.3 Inspect if support frame mounting sleeves on left and right crankcases are damaged.

2.4 Inspect if oil seal $\varnothing 19.8 \times \varnothing 30 \times 5$ is in good condition and if sealing lip is hardened.

2.5 Inspect the condition of use of left and right crankshaft bearing holes. Limit of use: left crankcase crankshaft bore: 47.016mm ; right crankcase crankshaft bore: 42.016mm .

2.6 Rotate crankshaft bearing to inspect if there is abnormal sound or looseness. If there is, replace crankshaft assembly. (Figure 9-3)

2.7 Inspect looseness in directions X and Y at shaft right angle of crankshaft connecting rod big end. Limit of use: if X, Y radial gap $> 0.05\text{mm}$, effect replacement (Figure 9-4); if assembly play $> 0.5\text{mm}$, effect replacement (Figure 9-3).

2.8 Inspect for easy rotation of connecting rod crank, inspect wear of connecting rod small end bore, standard value: $\varnothing 13.024 \sim \varnothing 13.006\text{mm}$. Limit of use: if bore $D > 13.05\text{mm}$, effect replacement (Figure 9-4).

2.9 Inspect if there is wear or damage of timing chain sprocket and if there is, effect replacement. (Figure 9-3)

2.10 Inspect crankshaft oscillation (Figure 9-5), limit of use: $\geq 0.6\text{mm}$.

3. Mount inspected and measured parts in an order reversed to that of dismounting. When crankcases are closed, rotate crankshaft connecting rod to inspect its easy rotation.

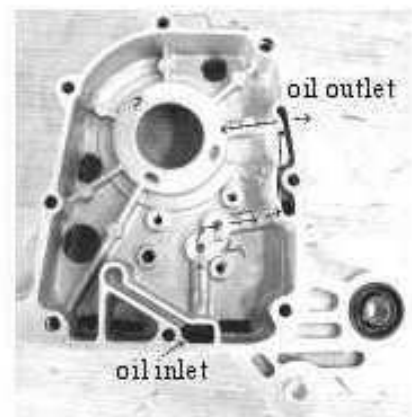

(Figure 9-2)

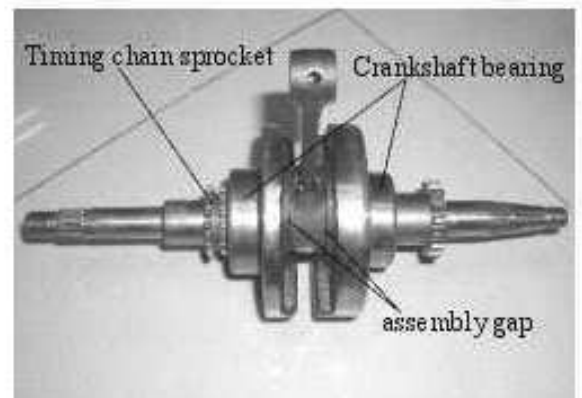

(Figure 9-3)

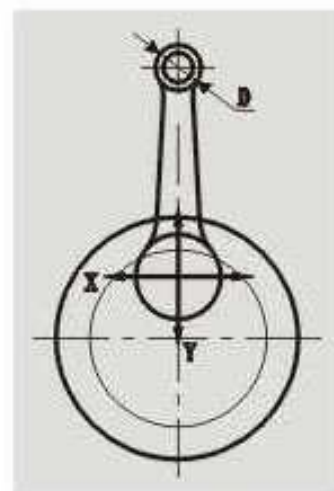

(Figure 9-4)



(Figure 9-5)

X. Timing Chain and Tensioner

1. It consists of timing chain, tensioner, tensioning plate assembly and guide plate assembly.

2. Timing chain and tensioner disassembling and inspecting

2.1 Remove tensioner spring set bolt M8x8 spring, remove 2 bolts M6x16 and tensioner. (Figure 10-1)

2.2 Place left crankcase below, remove right crankcase, crankshaft and finally remove timing chain. (Figure 10-2)

2.3 Remove tensioning plate set bolt and draw out tensioning plate.

2.4 Remove paper gasket material on the joining face between tensioner and cylinder body, inspect for normal extension of tensioner and fastness of trip. If not, effect replacement. (Figure 10-3)

2.5 Tensioner spring free length should be 45mm~50mm. If not, effect replacement (Figure 10-4)

2.6 Inspect if there is wear or damage of timing chain. If there is, effect replacement.

2.7 Inspect if there is wear, damage or serious deformation of tensioning plate. If there is, effect replacement. (Figure 10-4)

2.8 Inspect if there is wear, damage or serious deformation of guide plate. (Figure 10-4)

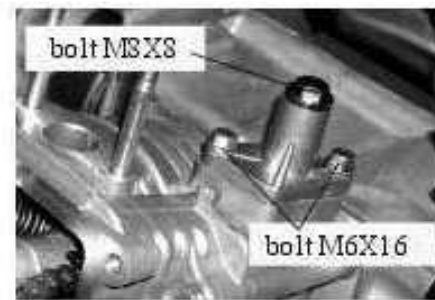

(Figure 10-1)



(Figure 10-2)



(Figure 10-3)

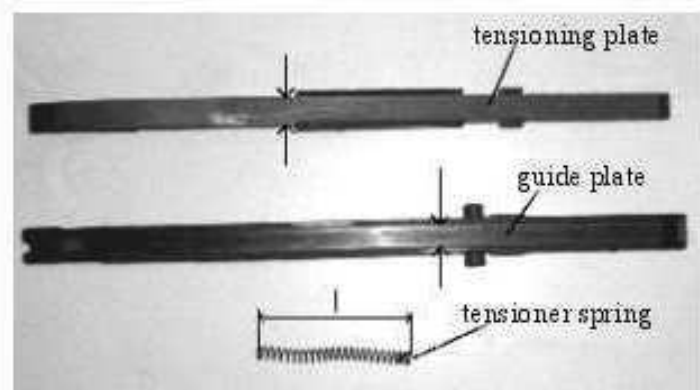

(Figure 10-4)

Mount inspected and measured parts in an order reversed to that of dismounting as technically specified.

Note A. Torque of tensioner mounting bolt M6x16: 10N.m.

B. Torque of tensioner bolt M8x8: 6N.m.

C. Apply sealing bond to both sides of tensioner sealing gasket.

XI. Lubrication System

1. Lubrication system mainly consists of engine oil filter, engine oil pump, engine oil passage, oiling plug, oil drain plug and engine oil gage, etc.

2 Lubrication system. (Figure 11-1)

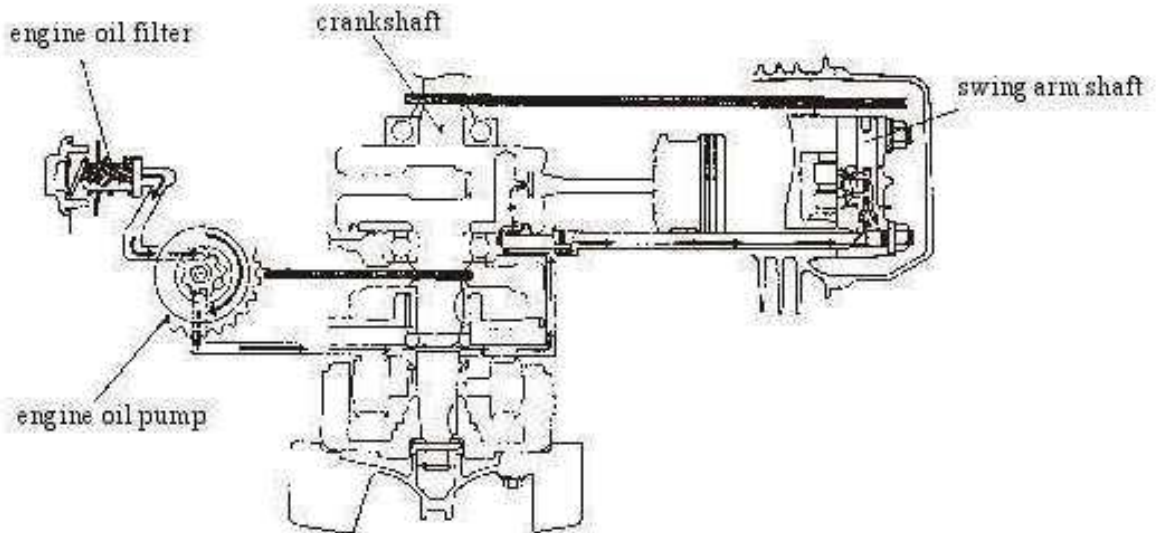

(Figure 11-1)

Engine oil is filled through engine oil depth gage hole, filtered through strainer, pumped by engine oil pump to main oil passage, one branch flows into crankshaft connecting rod through right crankcase shaft hole and is thrown to cylinder and piston and another branch flows into camshaft chamber through cylinder body and cylinder head oil passage, lubricates related parts and enters crankcase engine oil pool.

3. Precautions

- Usually, engine oil pump is not disassembled. Effect replacement as a whole in case of poor condition.
- After engine oil pump is mounted, inspect if oil pumping system is normal.

4 Trouble finding

4.1 Inadequate engine oil

- Natural consumption of engine oil
- Leakage of engine oil
- Wear of piston ring
- Damage of valve rod oil seal

4.2 Engine burn

- No oil pressure or low oil pressure
- Clogging of engine oil passage
- Absence of specified lubricant

5 Use and inspection

5.1 Engine volume inspection

- When inspecting engine oil quantity, motorcycle must be placed on a level ground.
- Inspect engine quantity when engine has run for 2-3 minutes and has paused for 2-3 minutes.
- Measure engine oil quantity with oil depth gage. When oil level is below the lower limit position, add specified oil to bring oil level to the upper (Figure 11-2)

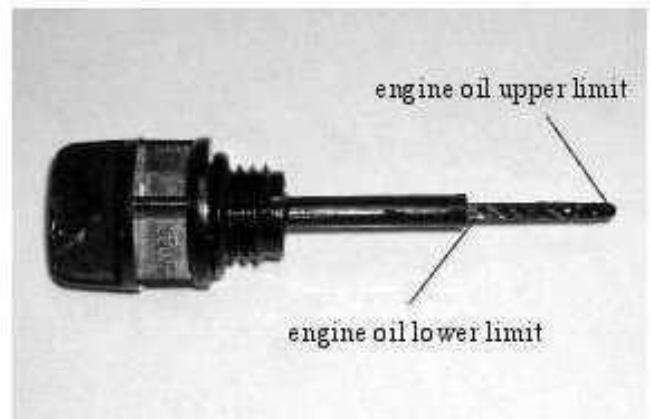

(Figure 11-2)

5.2 Engine oil changing

- Engine oil might flow out as engine warms up.
- Remove oil drain plug to let out engine oil.
- Remove and clean oil strainer and related parts.
- Inspect O-ring and effect replacement in case of damage or hardening.
- Fill 900ml of engine oil when disassembling engine and fill 750ml of engine oil when changing engine oil.

5.3 Correct remounting of parts after oil filling

5.4 When dismounted engine oil pump is remounted in engine, inspect if engine oil enters camshaft chamber.

XII. Rear Transmission

1. Rear transmission mainly includes rear transmission box, brake shoe mounting shaft, bearing 6004-2RS, bearing 6201/P6, bearing 6303X3/-2/P63, output shaft, input shaft, output gear, intermediate gear shaft, oil seal, etc.

2. Rear transmission disassembling and inspecting:

2.1 Remove driven gear, unscrew oil drain bolt

M8x12 and drain gear oil from transmission case. (Figure 12-1)

2.2 Place rear transmission case below, unscrew bolts M8x35 (2 bolts), M8x40 (5 bolts), remove rear transmission case, take out output shaft, output gear, intermediate gear and washers. (Figure 12-2)

2.3 Remove 2 set pins M10x20, remove paper gasket material of rear transmission case with shovel and clean them. (Figure 12-2)

2.4 Unscrew nut M8, remove brake shoe mounting shaft (Figure 12-3).

2.5 Inspect if there is burn, wear or damage of input shaft, intermediate gear shaft, output gear shaft and output shaft.

2.6 Inspect if there is abnormal noise or loosening of bearings. If there is, replace bearing with special bearing remover (Figure 12-4)

2.7 When replacing bearing 6004-2RS, remove oil seal $\phi 27 \times \phi 42 \times 7$ (Figure 12-3) before driving out bearing.

Mount inspected or replaced parts in an order reversed to that of dismounting as specified.

Note:

A. Remember to mount washers in intermediate gear shaft.

B. Apply sealing bond to both sides of rear transmission paper gasket.

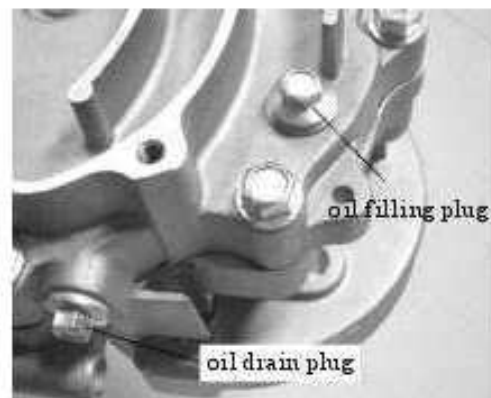

(Figure 12-1)

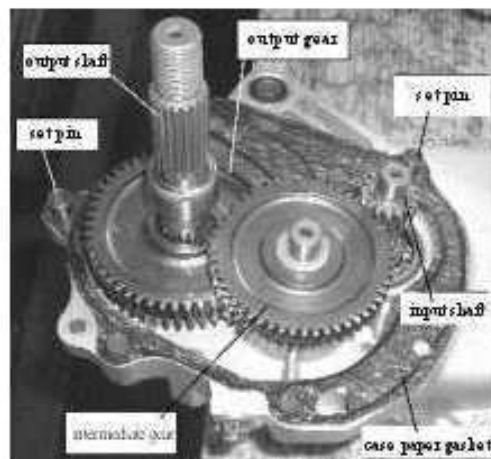

(Figure 12-2)

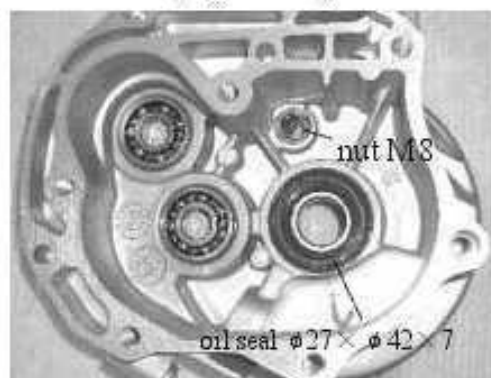

(Figure 12-3)



(Figure 12-4)

- C. Use brand new oil seal $\phi 27 \times \phi 42 \times 7$ and oil seal $\phi 17 \times \phi 30 \times 6$ for replacement. Avoid tilting of oil seal and bending of lip.
- D. Bearings must be correctly fitted to avoid slanting or flattening with bearing press-in depth and end run-out $< 0.04\text{mm}$.
- E. Brake shoe mounting shaft O-ring should be replaced and coated with sealing bond. O-ring should be free from edge clipping.
- F. Torque of bolts output M8*35 and M8*40: 20~22N·m
- G. At the completion of rear transmission assembling, rotate input shaft or output shaft to ascertain easy rotation.
- H. This motorcycle is not equipped with gear oil chamber vent tube. When engine is slanted or with excessive engine oil, oil dripping might occur at labyrinth seal. The oil can be wiped away or dripped out.
- I. After disassembling, 110ml gear oil should be added.

XIII. Carburetor

1. Precautions in carburetor maintenance and adjustment

- Gasoline is flammable, so worksite should be away from flame or electric spark.
- Gasoline evaporates, so operations must be performed at a well-ventilated place.
- When disassembling, loosen oil drain screw to let out gasoline into a container.
- Clean carburetor with compressed air.
- Drain gasoline from float bowl when carburetor is not to be used for a period of time as gasoline kept for a long time in float bowl would deteriorate and clog oil nozzle and would affect stability of engine performance.

2. Basic structure of carburetor

Diaphragm carburetor in BT139 engine mainly consists of control system, oil inlet system, low-speed oil supply system, high-speed oil supply system, starting priming valve, accelerating priming device, etc.

3. Carburetor disassembling, cleaning and inspecting:

Remove from motorcycle seat cushion and store box, loosen carburetor seat bolt A, air filter air inlet pipe bolt B, loosen nut to remove oil valve cable and air inlet pipe and then dismount carburetor. (Figure 13-1)

3.1 Disassembling float bowl sump:

Remove float bowl connecting screw, float bowl sump and rubber seal gasket. (Figure 13-2)

- Remove impurities and residue in float bowl.
- Inspect if float bowl seal gasket is hardened or damaged. If yes, effect replacement.

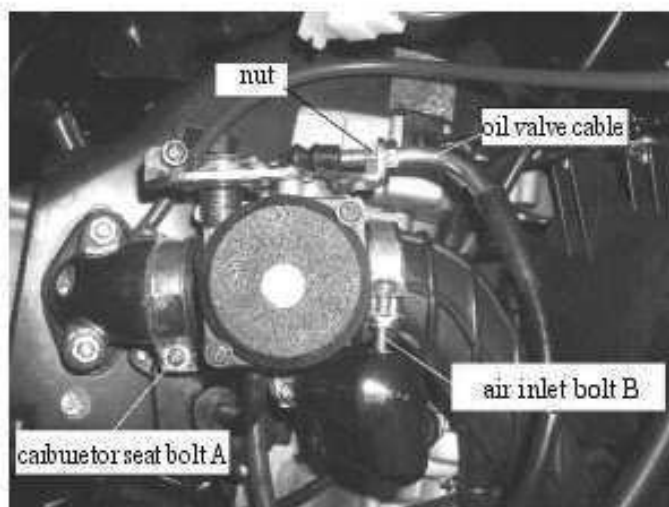

(Figure 13-1)

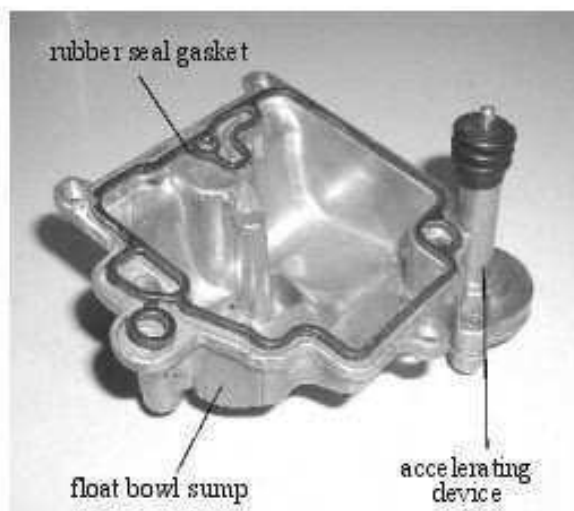

(Figure 13-2)

3.2 Float disassembling and adjusting.

Remove screw, float and needle valve. (Figure 13-3)

- Remove impurities on float surface;
- Remove impurities and condensed gel in gasoline on contact face between needle valve and valve seat.
- Inspect if wear of needle and wear of valve seat is serious, if yes, replace needle valve. In case of necessity, adjust needle hanger to enable float to keep required oil level.

3.3 Main nozzle and idler nozzle disassembling and inspecting.

Use special tools to prevent deformation of parts.

Remove main nozzle and idler nozzle. (Figure 13-3)

- Clean main nozzle and idler nozzle with carburetor special cleaning solvent or industrial gasoline.
- Clean all jets with compressed air. Do not wipe them with flashing cloth or paper so as to avoid recontamination.
- Never poke main nozzle or idler nozzle with hard objects such as steel wire so as to avoid changes in carburetor performances due to changes in bores.

3.4 Diaphragm vacuum piston valve disassembling and inspecting

Unscrew 2 screws of carburetor top cover, remove diaphragm, remove return spring, diaphragm vacuum piston valve oil needle. (Figure 13-4)

- Inspect if free extension of spring is normal and if not, effect replacement. (Figure 13-5)
- Clean diaphragm vacuum piston valve with compressed air and inspect if diaphragm is in good state and if not, effect replacement. (Figure 13-5)
- Inspect if oil needle is deformed or worn and if O-ring is in good state, and if not, effect replacement. (Figure 13-6)

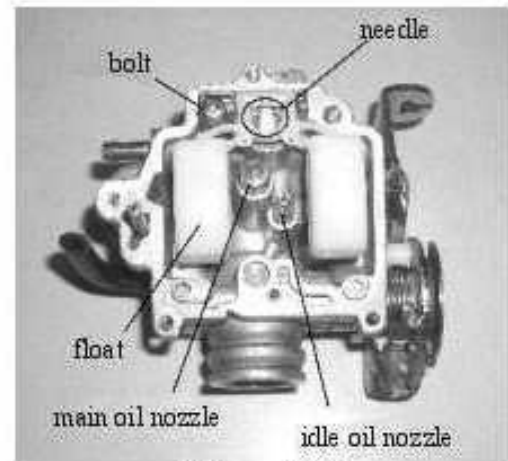

(Figure 13-3)



(Figure 13-4)



(Figure 13-5)

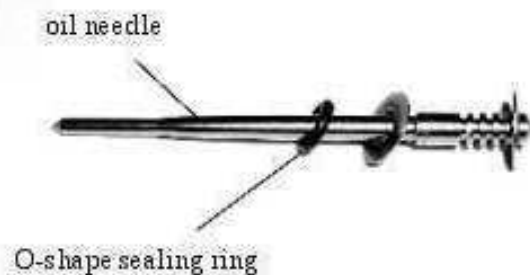

(Figure 13-7)

3.5 Starting primer valve disassembling and inspecting

Remove 2 bolts and starting primer valve (Figure 13-4).

- Inspect if there is damage of starting primer valve O-shape seal ring and if there is, effect replacement.
- Clean with compressed air starting primer valve and priming passage of carburetor. (Figure 13-7)
- Inspect primer valve plunger movement 5 minutes after starting primer valve circuit is on. If primer plunger extends as spring extends, priming is normal, if not, heater in primer valve is damaged and priming valve assembly should be replaced.

3.6 Mount carburetor parts in an order reversed to that of dismounting, noting:

- Never effect one-step tightening of connecting screws of float bowl, tighten them in two or three steps at a tightening torque of 12~15N.m. Otherwise deformation of connecting face or oil leakage or air leakage shall occur.
- Tightening torque of jet parts is usually 1.5~3.0N.m. Excessive torque shall damage thread and lead to deformation of parts.
- When mounting diaphragm piston valve, note that sting on diaphragm is aligned with drop pit of carburetor so as to allow only the covering of diaphragm rim instead of the complete covering of diaphragm by covering plate. (Figure 13-8)
- As position of idle mixed gas adjusting screw is vital to the performance of motorcycle exhaust, idle speed, transition and oil consumption, idle mixed gas adjusting screw is usually not turned when cleaning carburetor (Figure 13-7). In time of absolute necessity for dismounting, turn it home while remembering the number of turns (accurate to 1/8 turn) and when mounting, turn it back in the same number of turns. Standard turns of unscrewing $2 \pm 1/2$ turns.

4. Carburetor idle speed adjustment:

4.1 Carburetor lower idle speed adjustment

Misfire soon after engine starting is due to inadequate opening of oil valve. Turn clockwise idle speed adjusting screw on control system racket (Figure 13-9). When engine speed is too high, turn it out counterclockwise and when engine speed is too lower, adjust engine idle speed to about 1900 ± 100 r/min.

4.2 Carburetor unstable idle speed adjustment:

Instability of idle speed: After a few minutes running of engine, speed fluctuates between ± 100 r/min. In such case, adjust idle speed mixed gas adjusting screw to optimal position for solution. The method is as follows: First, adjust idle speed adjusting screw on control system racket to an engine speed slightly higher than usual speed. Turn idle speed mixed gas adjusting screw right and left to find the highest speed at this position, then slightly adjust idle speed adjusting screw to a lower engine speed and turn idle speed mixed gas adjusting screw to find the highest speed. Repeat this operation till a certain speed is equal to standard idle speed.

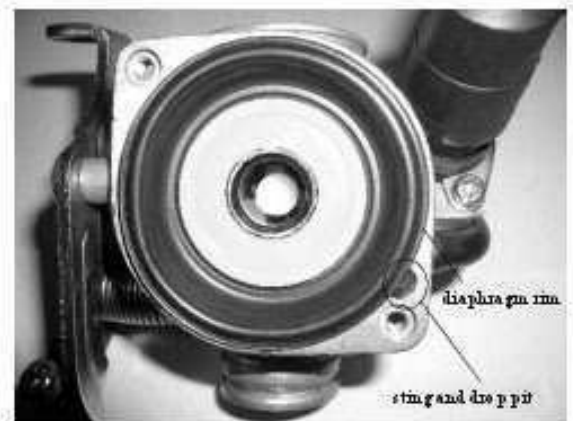

(Figure 13-8)

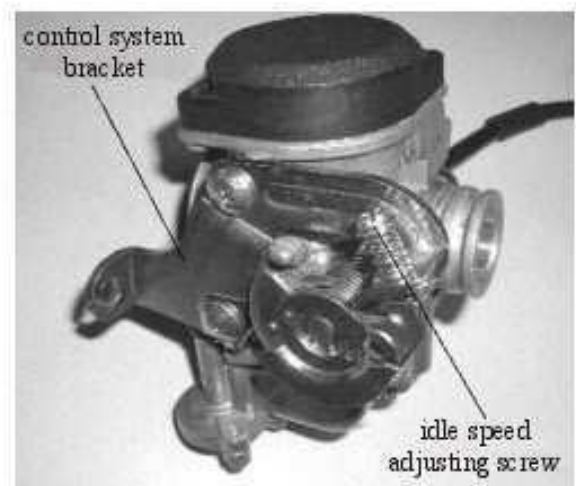

(Figure 13-9)

5. Carburetor troubleshooting and maintenance:

Carburetor's function is to ensure suitable supply of gasoline-air mixed gas to engine under different working conditions. As oil gas pores in many carburetor parts are small, they are apt to be deformed or clogged and as a result, the function of carburetor may change and troubles in motorcycle riding may occur due to impurities, colloid or impurities in the air. Carburetor troubles and troubleshooting are as follows:

5.1 Difficult starting

Difficult starting means that engine does not keep continuous running after 15 -minute kick starting or electric starting with correct operation of handlebar oil valve. Main causes of troubles and corresponding troubleshooting methods:

A. Absence of fuel in carburetor float bowl.

Cause: Clogged oil inlet passage.

Troubleshooting: Remove carburetor float bowl cover, clean all its parts, inspect all the oil passages and air passages, inspect the function of fuel filter and if it is defective, effect replacement.

B. Ineffective priming device:

Causes: 3~5 minutes after motorcycle electric switch is turned on, touch the plastic outer case of electrothermal starter. The circuit is normal if it is warm and if otherwise, inspect circuit. In case electric circuit is normal, primer is defective.

Troubleshooting: The same as disassembling and inspecting of starting primer valve stated above.

5.2 Poor transition

In the process of accelerating, engine speed remarkably fluctuates or misfires.

A. Cause: Clogging of carburetor jets or foam pipes.

Troubleshooting: Clean as carburetor is cleaned as stated above.

B. Cause: In the process of transition, oil supply to carburetor is mainly from idle speed oil system and in case idle system is not in good condition, transition shall be affected.

Troubleshooting: Adjust idle speed adjusting screw to find optimal adjustment position for adjustment, as stated above.

5.3 Inadequate power

It finds expression in inadequacy in accelerating function and high-speed function:

- An obvious feeling of reduced accelerating and driving function.
- Reduced high-speed with "thrust" of motorcycle and abrupt air-bleeding from exhaust pipe.

A. Cause: Clogging of idle speed oil nozzle or main oil nozzle

Troubleshooting: Clean as carburetor is cleaned, as stated above.

B. Cause: Clogging of idle speed oil passage, air passage, main oil passage or air passage.

Troubleshooting: Same as above.

C. Cause: Clogging of quick priming device or ineffective diaphragm.

Troubleshooting: Clean accelerating pump oil passage with compressed air, inspect if diaphragm is effective and if not, effect replacement.

5.4 Irregular oil level of carburetor leading to irregular oil supply.

Cause: A. Foreign matter on contact face between needle valve and valve seat;

B. Worn needle valve,

D. Float with mould or fracture leading to oil leakage.

Troubleshooting: A. Clean carburetor,

B. Replace needle valve,

A. Clean carburetor and replace float.

XIV. Air Filter

Loosen carburetor tube clamp screw (Figure 14-1), loosen vent pipe circlip and remove 2 bolts M6 x 30 (Figure 14-2) which connect air filter and case body. Remove air filter, air filter cover screw and parts.



(Figure 14-1)

Inspect all parts and if they are dirty, clean them and in case of damage, effect repair or replacement. Air filter strainer (Figure 14-3) maintenance and service intervals: inspect or replace every 5000km. After cleaning, apply a small amount of grease to strainer to increase its absorptivity to dust. Mount inspected and cleaned parts in an order reversed to that of dismounting.

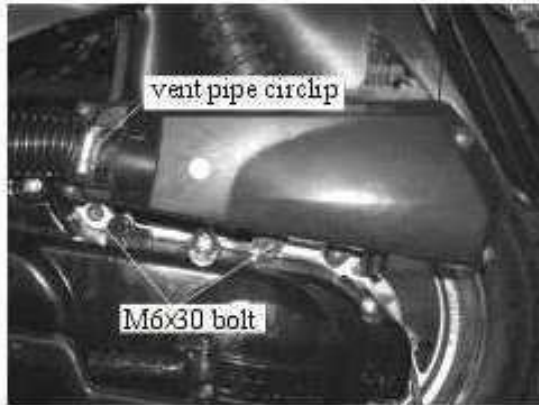

(Figure 14-2)



(Figure 14-3)

ATTACHED PAGES
SPECIAL TOOLS:



Flywheel remover (Z01)



Valve adjusting fixed wrench (Z02)



Spark plug special sleeve (Z03)

Universal tools:

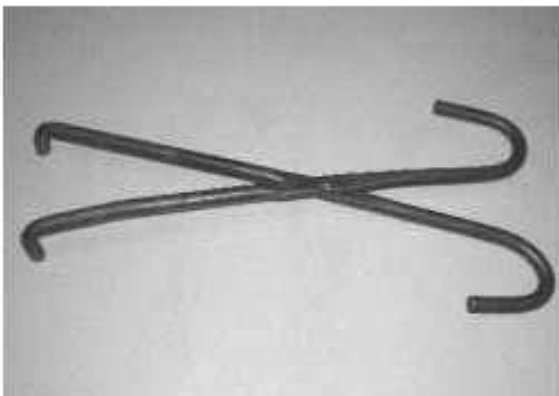

Fixing bracket (Y01)

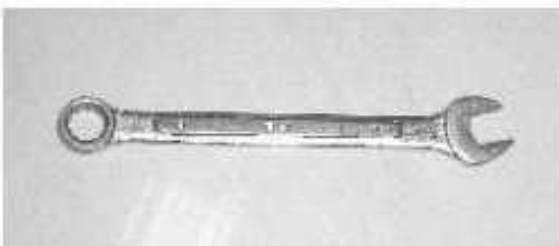

Closed wrench 9# (Y02)

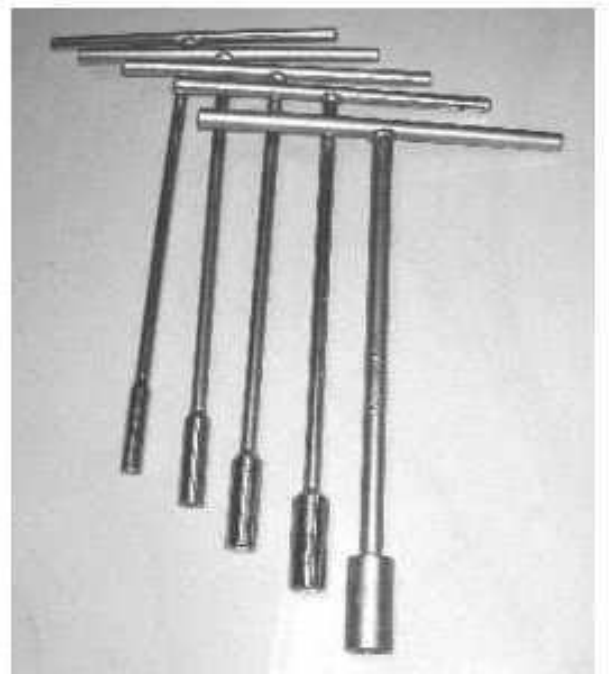

"T" sleeve: 8", 10", 12", 14", 17"
(T8, T10, T12, T14, T17)

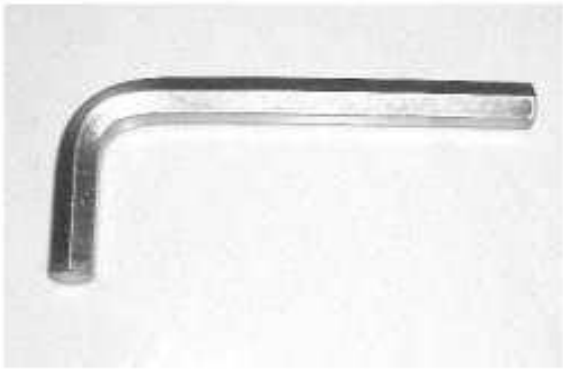

Hexagon wrench 8# (Y03)



“+” screw driver (Y05)



Sharp-nose pliers (Y07)



Ratchet wrench (Y09)



Internal thread screw driver head:
M6×1 M7×1.25
(YM6, YM7)



Spade (Y04)



Rubber mallet (Y06)

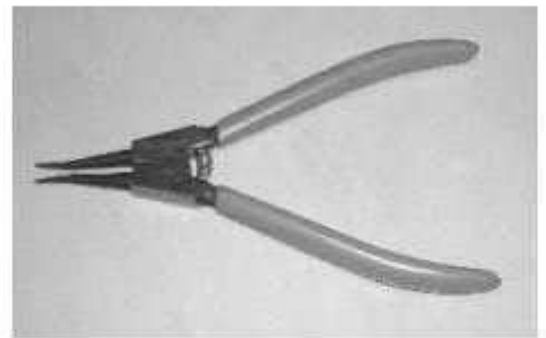

Clip ring pliers (Y08)



Sleeves 14#, 17# (YT14, YT17)



Round head screw driver (Y10)